

# MATHEMATICS 3000



# MATHEMATICS

# 3000

*Cultural, Social  
and Technical*

OPTION

Québec Education Program

SOLUTION

Secondary 5

Gérard Buzaglo

Chantal Buzaglo



Guérin Montreal  
Toronto  
4501 Drolet Street  
Montreal (Quebec) Canada H2T 2G2  
Telephone: 514-842-3481  
Fax: 514-842-4923  
Internet: <http://www.guerin-editeur.qc.ca>  
E-mail: [francel@guerin-editeur.qc.ca](mailto:francel@guerin-editeur.qc.ca)

Translator  
*Doug Neal*

© Guérin, éditeur liée, 2009

All rights reserved.  
No part  
of this book  
may be reproduced,  
recorded or transmitted  
in any form by any means,  
whether electronic, mechanical,  
photographic, sonor, magnetic or other,  
in whole or in part, without prior permission  
in writing from the publisher.

Legal deposit

ISBN 978-2-7601-7103-9

Bibliothèque et Archives nationales du Québec, 2009  
Bibliothèque et Archives Canada, 2009

PRINTED IN CANADA

We acknowledge the financial support of the Government of Canada through the Book  
Publishing Industry Development Program for our publishing activities.

**Canada**

**PHOTOCOPYING KILLS BOOKS**

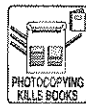

# Introduction

At the beginning of the third millennium, Guérin, éditeur is pleased to make available to Quebec teachers the exercise book, Math 504, **Cultural, Social and Technical option**, of the **Mathematics 3000** collection.

This is an exercise book whose content, in accordance with the Quebec Education Program, is geared towards skill development, especially the three disciplinary skills: “**Solving a situational problem**”, “**Using mathematical reasoning**”, and “**Communicating by using mathematical language**”.

Each book in the collection is divided into chapters that cover the various fields of mathematics such as arithmetic, algebra, geometry, probabilities and statistics.

Each chapter begins with the **Challenge** section where the student is invited, alone or in a team, to **solve situational problems** that have not been presented previously. The solution of each situation requires a combination of rules or principles that the student may have learned or not. In this section, the student is confronted with various situations that will provide him with the motivation to seek inside the chapter the elements allowing him to solve them.

Each of the other sections of a chapter starts with **learning activities** where the student is led step by step to the discovery of the concepts. Activities lead to highlighted **sections** summarizing the essential material of the course, and supported by **examples**. The student will find, in these highlights, complete references that will be useful throughout his learning process. The highlights are followed by a series of graded **exercises and problems** that will allow the student to **develop his skills** by solving situational problems, by using mathematical reasoning and by communicating using mathematical language. Each time the situation allows it, the student will have to explain the steps he used, justify his reasoning and finally communicate his answer in an appropriate manner.

Each chapter ends with an **Evaluation** section that will allow the student to ascertain if the knowledge has been acquired and if the skills have been attained.

A detailed list of **symbols** and an **index** at the end of each book will allow the student to easily find everything he needs during his learning.

This pedagogical tool, focused on skill development, is written in a clear and simple language and aims to be accessible to every student without sacrificing mathematical rigor.



# Table of Contents

## Chapter 1 *Optimization* 1

### CHALLENGE 1 3

- 1.1 Two-variable first degree equations 4
- 1.2 Two-variable first degree inequalities 7
- 1.3 System of two-variable first degree equations 12
- 1.4 System of two-variable first degree inequalities 15
- 1.5 Polygon of constraints 18
- 1.6 Optimization of a situation 22

### EVALUATION 1 30

## Chapter 2 *Graphs* 35

### CHALLENGE 2 37

- 2.1 Graphs 38
- 2.2 Chains 45
- 2.3 Various graphs 54
- 2.4 Optimization problems 60

### EVALUATION 2 70

## Chapter 3 *Transformations in the Cartesian plane* 75

### CHALLENGE 3 77

- 3.1 Translation 78
- 3.2 Rotation 83
- 3.3 Reflection 86
- 3.4 Scaling 90
- 3.5 Homothety 93
- 3.6 Properties of transformations 97
- 3.7 Sequence of transformations 103

### EVALUATION 3 112

## **Chapter 4** *Equivalent figures* 115

### **CHALLENGE 4** 117

- 4.1 Area and volume of solids 118
- 4.2 Equivalent plane figures 121
- 4.3 Equivalent solids 124
- 4.4 Comparing of polygons 127
- 4.5 Comparing of solids 133

### **EVALUATION 4** 136

## **Chapter 5** *Probabilities* 139

### **CHALLENGE 5** 141

- 5.1 Arrangements and combinations 142
- 5.2 Voting procedures 146
- 5.3 Events 151
- 5.4 Operations between events 153
- 5.5 Probability of an event 160
- 5.6 Axioms and theorems 162
- 5.7 Conditional probability 170
- 5.8 Independent events 177
- 5.9 Problems 180

### **EVALUATION 5** 182

### **SYMBOLS** 185

### **INDEX** 189

### **INDEX OF THEOREMS** 193



# Chapter 1

## *Optimization*

### **CHALLENGE 1**

- 1.1** Two-variable first degree equations
- 1.2** Two-variable first degree inequalities
- 1.3** System of two-variable first degree equations
- 1.4** System of two-variable first degree inequalities
- 1.5** Polygon of constraints
- 1.6** Optimization of a situation

### **EVALUATION 1**



# CHALLENGE 1

1. During the summer, Adel grows strawberries on his farm in the St-Laurent Lowlands. His wife Denise makes jam that she sells in her general store. She fills 400 ml jars and 500 ml jars.
- Every week she uses a maximum of 30 litres of jam.
  - She wants to produce at least 50 jars per week.
  - She also wants to produce, weekly, at least 20 jars but at most forty 500 ml jars.
  - Moreover, she wants to produce, weekly, at least twenty 400 ml jars.

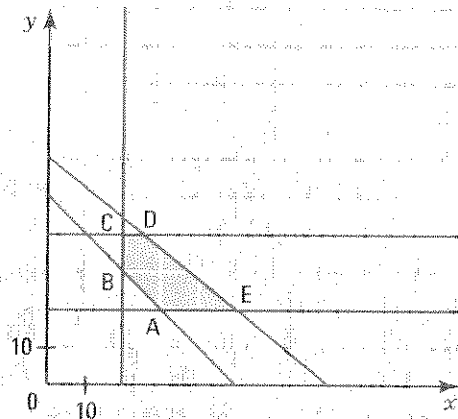

How many jars of each size must she produce weekly in order to maximize her profit if she sells each 400 ml jar for \$7 and each 500 ml jar for \$9?

$x$ : number of 400 ml jars

$y$ : number of 500 ml jars

$$x \geq 0$$

$$y \geq 0$$

$$400x + 500y \leq 30\,000$$

$$x + y \geq 50$$

$$20 \leq y \leq 40$$

$$x \geq 20$$

Vertices	$R = 7x + 9y$
A(30, 20)	\$390
B(20, 30)	\$410
C(20, 40)	\$500
D(25, 40)	\$535
E(50, 20)	\$530

She will maximize her profit if she produces, weekly, twenty-five 400 ml jars and forty 500 ml jars.

# 1.1 Two-variable first degree equations

## ACTIVITY 1 Laying sod in a yard

Mr. Quinn would like to have sod installed in his rectangular yard. The length of the yard is 50 m more than twice its width. The perimeter of the yard is equal to 340 m.

- a) Establish an equation that translates this situation.

$6x + 100 = 340$  where  $x$  represents the width of the yard.

- b) Determine the dimensions of the yard.

Length: 130 m and width: 40 m.

- c) Find the cost of the sod, knowing that it costs \$0.80/m<sup>2</sup>. **\$4160**

### ONE-VARIABLE FIRST DEGREE EQUATION

- A one-variable first degree equation is an equation that can be written as:

$$ax + b = 0 \quad a \neq 0$$

Ex.:  $2x + 6 = 0$  is a one-variable first degree equation.

- Solving a first degree equation in one variable  $x$  consists in finding the value of  $x$  which transforms the equation into a true equality. The value of  $x$  we obtain is called solution of the equation.

Ex.:  $3x - 5 = 13$

$\downarrow + 5$        $\downarrow + 5$       We add 5 to both sides of the equation.

$3x = 18$

$\downarrow \div 3$        $\downarrow \div 3$       We divide each side of the equation by 3.

$x = 6$

The solution of the equation is 6.

## ACTIVITY 2 Two-variable first degree equation

Consider the two-variable first degree equation  $2x - 5y = -10$ .

- a) Do the coordinates of the point A(5,4) verify this equation?

**Yes**

- b) Find two other points B and C whose coordinates verify this equation. **B(0, 2), C(-5, 0)**

- c) Place points A, B and C in the Cartesian plane on the right. What is the position of these three points? **They are aligned.**

- d) What is the solution set of the equation  $2x - 5y = -10$ ? Represent it in the Cartesian plane.

**The solution set is a line.**

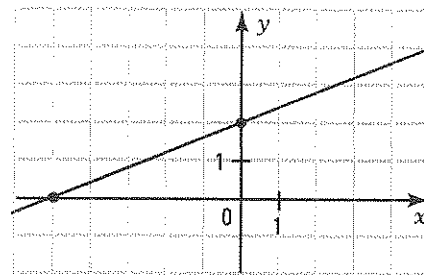

## ACTIVITY 3 Manufacturing furniture

A furniture manufacture makes chairs and armchairs. The number of hours spent on finishing a chair is 3 hours and the number of hours spent finishing an armchair is 5 hours. In one week, the time spent on finishing these two pieces of furniture is equal to 45 hours.

- a) If  $x$  and  $y$  represent respectively the number of chairs and the number of armchairs produced in one week, translate into a two-variable equation the constraint stating that the total time spent during one week to make these two items is 45 hours.

$$3x + 5y = 45$$

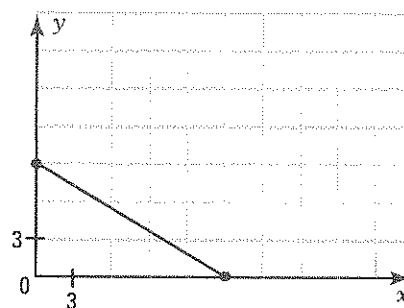

- b) Construct a table of values satisfying the constraint established in a).

$x$	0	5	10	15
$y$	9	6	3	0

- c) In this situation, the variables  $x$  and  $y$  take only positive values. Represent the solution set of the equation established in a) in the 1st quadrant above.

### TWO-VARIABLE FIRST DEGREE EQUATION

- A two-variable first degree equation is an equation that can be written as:

$$ax + by + c = 0 \quad a \neq 0, b \neq 0$$

- The solution set of such an equation is represented graphically by a line.

Ex.: Consider the equation  $3x - 4y + 12 = 0$ .

Table of values

$x$	-4	0	4
$y$	0	3	6

The solution set of the equation  $3x - 4y + 12 = 0$  is represented by the set of points on the line on the right.

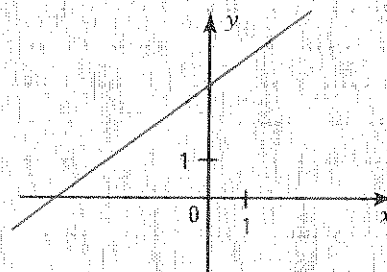

1. Determine if the coordinates of the point  $P(-2, 3)$  verify each of the following equations.

a)  $3x + 4y = 6$

b)  $-2x + y = 5$

c)  $y = 5x + 7$

d)  $\frac{x}{2} + \frac{y}{1.5} = 1$

Yes

No

No

Yes

2. Represent graphically the solution set of each of the following equations.

a)  $3x + 4 = 10$

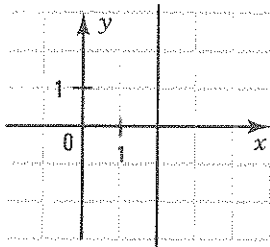

b)  $x + y = 2$

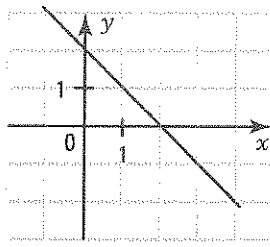

c)  $x + 2y = 3$

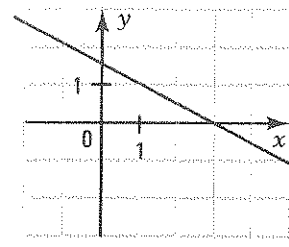

d)  $3x - 2y = 3$

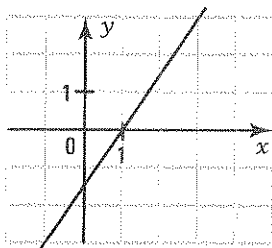

e)  $y = -2x + 4$

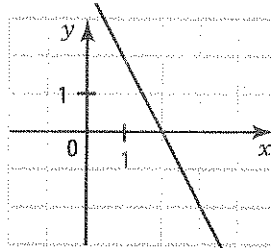

f)  $4y = -4$

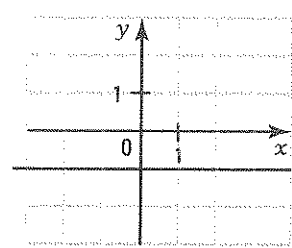

3. The management of a tennis club wishes to hire personnel for its summer season. It wants to hire instructors and attendants. If  $x$  represents the number of instructors and  $y$  the number of attendants, translate each of the following constraints into a two-variable first degree equation.

a) The total number of people hired is equal to 8.  $x + y = 8$

b) The number of instructors exceeds the number of attendants by 4.  $x = y + 4$

c) There are three times as many instructors as attendants.  $x = 3y$

d) The number of instructors increased by twice the number of attendants is equal to 10.

$x + 2y = 10$

e) The number of attendants is equal to one third the number of instructors decreased by 1.

$y = \frac{1}{3}x - 1$

4. A grocery store produces strawberry jam. It produces 250 ml jars and 500 ml jars. The total quantity of jam it wants to package is 6000 ml.

a) Define the variables in this situation.

$x$ : number of 250 ml jars,  $y$ : number of 500 ml jars.

b) Translate this situation into a two-variable first degree equation.

$250x + 500y = 6000$

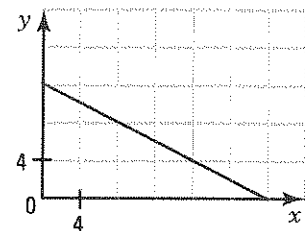

c) Represent the solution set of the equation established in b) in the Cartesian plane on the right.

d) Give a solution couple for this equation. What does it represent?

$(16, 4)$ . The grocery store can produce sixteen 250 ml jars and four 500 ml jars.

# 1.2 Two-variable first degree inequalities

## ACTIVITY 1 Fence around a field

M. Addison would like to put a fence around a rectangular field whose length measures 6 m more than three times its width. He has a maximum of 84 m of fencing.

- a) Write an inequality that translates this situation.

*x*: length of the field;  $2(3x + 6) + 2x \leq 84$ ;  $8x + 12 \leq 84$

- b) In which interval is the width of this field contained?

$x \leq 9$ . The width of the field is contained in the interval  $]0, 9]$ .

## ACTIVITY 2 Properties of the inequality relation

Let  $a$ ,  $b$  and  $c$  be any three real numbers. Complete the following equivalences using the appropriate symbol  $\geq$  or  $\leq$ .

a)  $a \leq b \Leftrightarrow a + c \leq b + c$ .

b)  $a \leq b \Leftrightarrow a - c \leq b - c$ .

c) 1.  $a \leq b$  and  $c > 0 \Leftrightarrow ac \leq bc$ .

2.  $a \leq b$  and  $c < 0 \Leftrightarrow ac \geq bc$ .

d) 1.  $a \leq b$  and  $c > 0 \Leftrightarrow \frac{a}{c} \leq \frac{b}{c}$ .

2.  $a \leq b$  and  $c < 0 \Leftrightarrow \frac{a}{c} \geq \frac{b}{c}$ .

### ONE-VARIABLE FIRST DEGREE INEQUALITY

- A one-variable first degree inequality is an inequality that can be written as:

$$ax + b \geq 0 \quad a \neq 0 \quad (\leq, >, <)$$

Ex.:  $3x + 9 \geq 0$  is a one-variable first degree inequality.

- Solving a first degree inequality in one variable  $x$  consists in finding the set of solutions that transforms the inequality into a true inequality.

Ex.:  $-2x + 3 \geq 15$

$$\begin{array}{l} \downarrow -3 \quad \downarrow -3 \\ -2x \geq 12 \end{array}$$

We subtract 3 from both sides of the inequality.

$$-2x \geq 12$$

$$\downarrow \div (-2) \quad \downarrow \div (-2)$$

$$x \leq -6$$

We divide each side of the inequality by  $-2$ .

We change the direction of the inequality because we divide each side by the negative number  $-2$ .

$$S = ]-\infty, -6]$$

### ACTIVITY 3 Two-variable first degree inequality

Consider the line  $l$  with equation:  $2x + 5y - 10 = 0$ . Line  $l$  divides the plane into 2 half-planes: the colored half-plane containing the origin  $O$  and the grey half-plane that doesn't contain it. This line  $l$  is called **boundary** for each of the half-planes. In which half-plane is the set of points verifying the following inequality located?

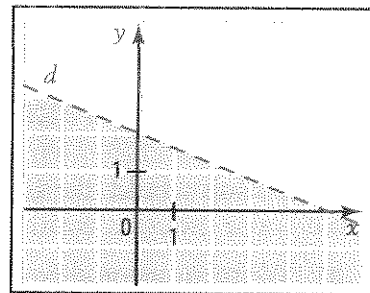

- a)  $2x + 5y - 10 > 0$ ? Grey half-plane.  
 b)  $2x + 5y - 10 < 0$ ? Colored half-plane.

### ACTIVITY 4 At a financial centre

A financial centre employs regular staff and contract staff. Each regular employee receives a \$20/hour salary and each contract employee receives a \$25/hour salary. The centre has a maximal budget of \$2000 per week.

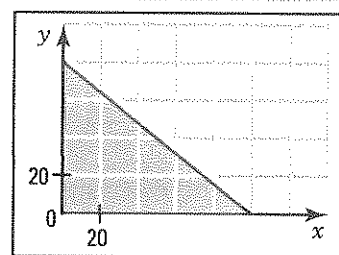

- a) If  $x$  represents the number of working hours of a regular employee and  $y$  represents the number of working hours of a contract employee, translate this situation into two-variable first degree inequality.  $20x + 25y \leq 2000$   
 b) Explain why the possible solutions for  $x$  and  $y$  must be in the 1st quadrant.  
 $x$  and  $y$  represent respectively a number of working hours, which is positive.  
 c) Draw the boundary line that divides the plane into two half-planes.  
 d) Color, in the 1st quadrant, the region of the plane that represents the solution set of the inequality given in a).  
 e) Give two solution couples for this inequality. Various answers.

### TWO-VARIABLE INEQUALITY – REPRESENTATION OF THE SOLUTION SET

The solution set of the two-variable first degree inequality  $ax + by + c > 0$  is represented by a half-plane whose boundary is the line  $l: ax + by + c = 0$ .

- Ex. To determine the solution set of the inequality  $2x + 3y - 6 \leq 0$ ,
- we draw the line  $l: 2x + 3y - 6 = 0$ , boundary of the half-plane we seek.
  - if the origin  $O(0, 0)$  verifies the inequality, the solution half-plane is the one that contains the origin.

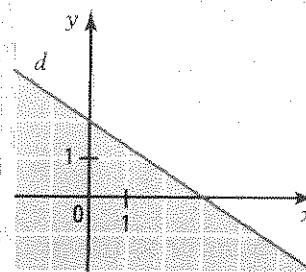

The boundary is drawn as a solid line to show that the points on the boundary are solutions, as a dotted line otherwise.

- we color the solution half-plane.

$$2x + 3y - 6 < 0$$

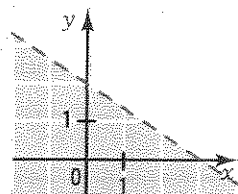

$$2x + 3y - 6 > 0$$

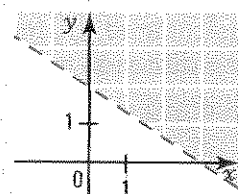

$$2x + 3y - 6 \geq 0$$

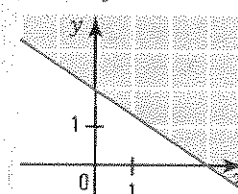



1. Represent graphically the solution set of the following inequalities.

a)  $-4x + 5y - 10 \leq 0$

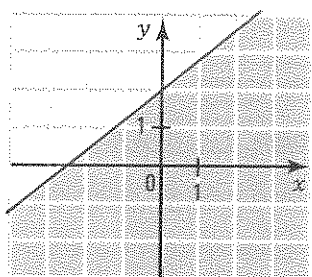

b)  $x - 3y < 0$

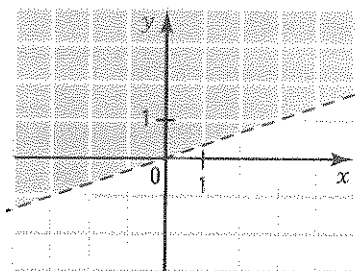

c)  $y > x - 2$

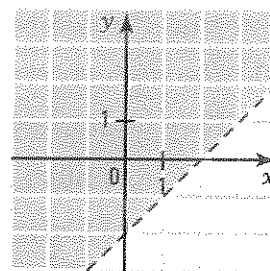

d)  $y \geq -1$

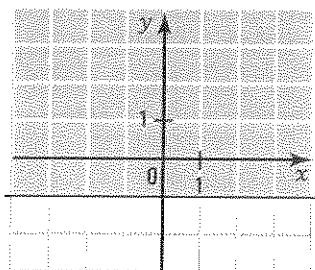

e)  $x \leq 3$

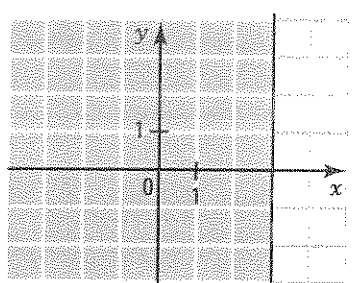

f)  $x + y \leq 3$

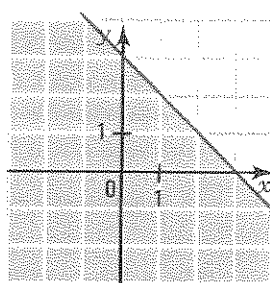

2. Determine if the coordinates of the point P(3, -2) verify each of the following inequalities.

a)  $5x - 4y > 10$

Yes

b)  $x \leq 4y$

No

c)  $x < 2y + 4$

No

d)  $-3x + 2y + 5 \leq 0$

Yes

e)  $x \leq 8$

Yes

f)  $\frac{x}{3} + \frac{y}{2} < 1$

Yes

3. For each of the following situations,

1. identify the variables.

2. translate the situation into a two-variable first degree inequality.

a) The total number of boys and girls on a field trip is less than or equal to 150.

$x$ : number of boys,  $y$ : number of girls;  $x + y \leq 150$ .

b) The perimeter of a rectangle is greater than 250 cm.  $x$ : length,  $y$ : width;  $2x + 2y > 250$ .

c) At a summer camp, counsellors are paid \$9.50 an hour and sports instructors are paid \$15 an hour. The budget for these employees' salary is less than \$9000.

$x$ : number of counsellors,  $y$ : number of sports instructors;  $9.50x + 15y < 9000$ .

d) At a food products company, salad dressing is packaged in 100 ml bottles and 250 ml bottles. The total amount of dressing packaged in bottles is at least equal to 50 litres.

$x$ : number of 100 ml bottles,  $y$ : number of 250 ml bottles;  $100x + 250y \geq 50\,000$ .

e) In a group of tourists, there are at most three times as many Francophones as there are Anglophones.

$x$ : number of Francophones,  $y$ : number of Anglophones;  $x \leq 3y$ .

4. To raise money for their graduation party, secondary 5 students sell shirts and caps. Each shirt sells for \$15 and each cap sells for \$8. Translate each of the following constraints into a two-variable first degree inequality, knowing that  $x$  represents the number of shirts sold and  $y$  represents the number of caps sold.

- a) The students want to raise at least \$850.  $15x + 8y \geq 850$
- b) They want to sell at most three times as many shirts as caps.  $x \leq 3y$
- c) They sold more than 70 items.  $x + y > 70$
- d) They sold a maximum of 40 shirts.  $x \leq 40$
- e) They sold at least as many shirts as caps.  $x \geq y$

5. At a fundraising concert to help homeless people, organizers sell adult tickets for \$25 and student tickets for \$10. If  $x$  represents the number of adult tickets sold and  $y$  represents the number of student tickets sold, use a two-variable first degree inequality to translate each of the following statements and represent the solution set of the inequality in the Cartesian plane with an appropriate choice of scale.

- a) The organizers raised more than \$4000.      b) There were at least four times as many adult tickets sold as student tickets.

$25x + 10y > 4000$

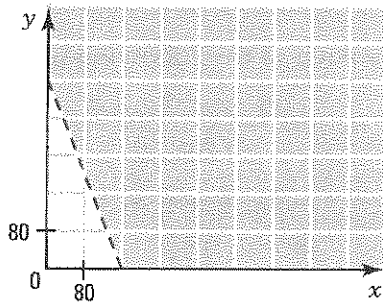

$x \geq 4y$

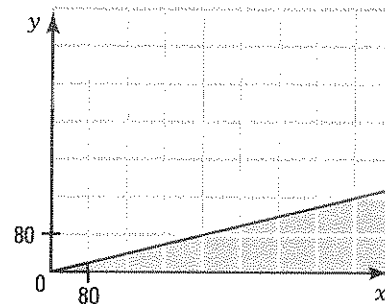

- c) The number of tickets sold is less than 400.      d) The number of adult tickets sold is greater than or equal to 240.

$x + y < 400$

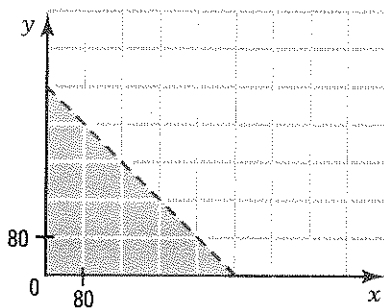

$x \geq 240$

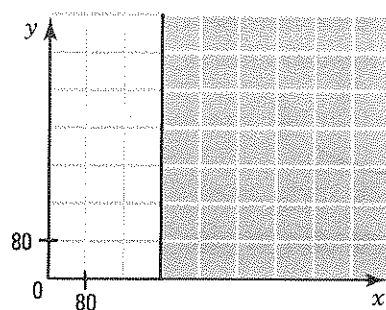

6. For each of the following situations,
1. define the variables involved in the situation;
  2. translate the situation into an inequality;
  3. represent the situation in the Cartesian plane.

- a) A garden has an area of 75 m<sup>2</sup>. Each fruit patch occupies 3 m<sup>2</sup> and each vegetable patch occupies 5 m<sup>2</sup>.

*x*: number of fruit patches,

*y*: number of vegetable patches;

$$3x + 5y \leq 75.$$

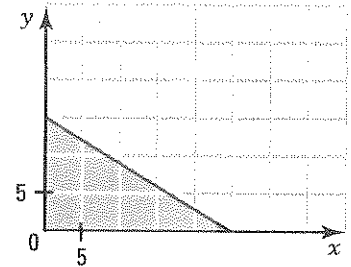

- b) In Quebec's logging industry, timber production exceeds pulp and paper production by at least 2%.

*x*: percentage of timber production,

*y*: percentage of pulp and paper production;

$$x \geq y + 2.$$

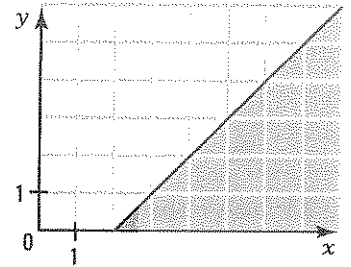

- c) Quebec's tourist industry announces that there are at least 6 times as many tourists from Quebec as there are tourists from other parts of Canada.

*x*: number of tourists from Quebec,

*y*: number of tourists from other parts of Canada;

$$x \geq 6y.$$

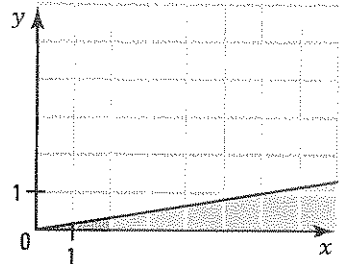

7. The manager of employees for a pharmaceutical company wishes to hire employees for the research department and employees for management. Research employees are paid \$40 an hour and management employees are paid \$16 an hour. If *x* represents the number of research employees and *y* the number of management employees, translate each of the following graphs into an inequality.

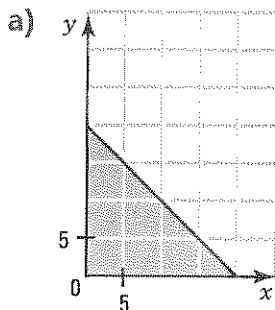

$$x + y \leq 20$$

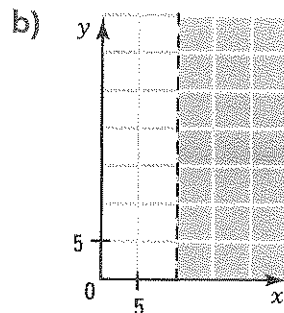

$$x > 10$$

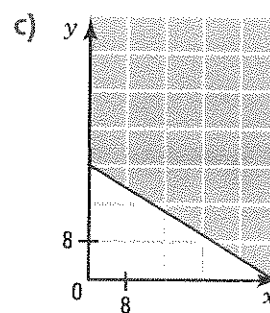

$$3x + 5y \geq 120$$

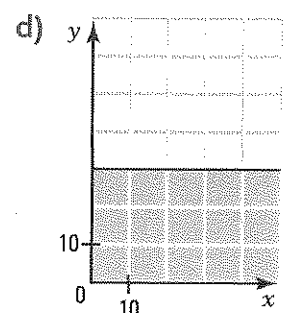

$$y \leq 30$$

# 1.3 System of two-variable first degree equations

## ACTIVITY 1 Methods for solving equations

- a) Represent, in the Cartesian plane on the right, the following system of equations and determine the solution set of the system.

$$\begin{cases} 2x + 5y = 1 \\ x = 2y + 5 \end{cases} \quad S = \{(3, -1)\}$$

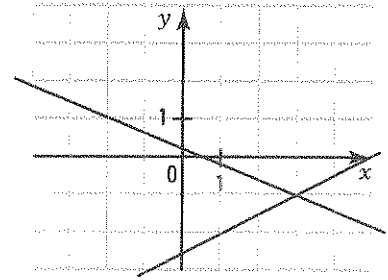

- b) Solve the following system using the addition method.

$$\begin{cases} 2x + 3y = 6 \\ 5x + 4y = 1 \end{cases} \quad S = \{(-3, 4)\}$$

- c) Solve the following system using the substitution method.

$$\begin{cases} 3x + 8y = 1 \\ x = 4y - 3 \end{cases} \quad S = \left\{ \left( -1, \frac{1}{2} \right) \right\}$$

- d) Solve the following system using the comparison method.

$$\begin{cases} y = 4x + 8 \\ y = 3x + 5 \end{cases} \quad S = \{(-3, -4)\}$$

### SYSTEM OF TWO-VARIABLE FIRST DEGREE EQUATIONS

- A system of two-variable first degree equations is a system that can be written as:

$$\begin{cases} a_1x + b_1y = c_1 \\ a_2x + b_2y = c_2 \end{cases}$$

where  $x$  and  $y$  are the variables and  $a_1, b_1, c_1, a_2, b_2, c_2$  are real numbers.

- Solving a system: Graphical method  
Solving graphically a system of two first degree equations consists in representing graphically each of the equations and determining the set of couples that verify both equations simultaneously.

Ex.: The solution set of the system  $\begin{cases} 3x + y = -5 \\ x + 2y = 0 \end{cases}$  is:  $S = \{(-2, 1)\}$

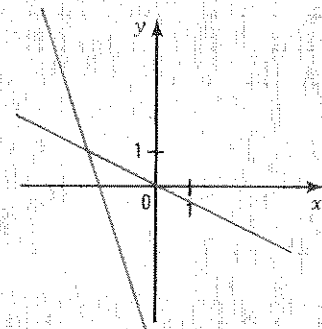

• Solving a system: Addition method

The addition method (also called reduction method) is illustrated in the following example.

Consider the system:  $\begin{cases} 2x + 5y = -4 \\ 3x - 2y = 13 \end{cases}$

- We multiply both members of each equation by a nonzero real number in order to have opposite coefficients for the variable  $x$  (or the variable  $y$ ).
- We add the corresponding sides of the equations in order to obtain an equation in only one variable.
- We determine the value of this variable.
- We, then, substitute the value obtained into one of the equations of the system and we deduce the value of the other variable.
- We establish the solution set  $S$  of the system.

$$\begin{aligned} &\times 3 \quad \begin{cases} 2x + 5y = -4 \\ 3x - 2y = 13 \end{cases} \\ &\times -2 \quad \begin{cases} 6x + 15y = -12 \\ -6x + 4y = -26 \end{cases} \\ &\qquad\qquad\qquad 19y = -38 \\ &\qquad\qquad\qquad y = -2 \\ &\qquad\qquad\qquad 2x + 5(-2) = -4 \\ &\qquad\qquad\qquad x = 3 \\ &\qquad\qquad\qquad S = \{(3, -2)\} \end{aligned}$$

• Solving a system: Substitution method

The substitution method is illustrated in the following example.

Consider the system:  $\begin{cases} 3x + 4y = -6 \\ 2x + y = 1 \end{cases}$

- We isolate one of the variables using one of the equations of the system.
- In the other equation, we substitute the isolated variable with the expression obtained.
- We solve the equation.
- We, then, substitute the value obtained into one of the equations of the system and we deduce the value of the other variable.
- We establish the solution set  $S$  of the system.

$$\begin{aligned} &\qquad\qquad\qquad y = -2x + 1 \\ &3x + 4(-2x + 1) = -6 \\ &3x - 8x + 4 = -6 \\ &\qquad\qquad\qquad x = 2 \\ &3(2) + 4y = -6 \\ &\qquad\qquad\qquad y = -3 \\ &\qquad\qquad\qquad S = \{(2, -3)\} \end{aligned}$$

• Solving a system: Comparison method

The comparison method is illustrated in the following example.

Consider the system:  $\begin{cases} -2x + y = 1 \\ 3x + 2y = 9 \end{cases}$

- We isolate the same variable in each equation.
- We deduce by transitivity an equation in only one variable.
- We solve the equation that we obtained.
- We substitute the value obtained into one of the equations of the system and we deduce the value of the other variable.
- We establish the solution set  $S$  of the system.

$$\begin{aligned} &\begin{cases} y = 2x + 1 \\ y = -\frac{3}{2}x + \frac{9}{2} \end{cases} \\ &2x + 1 = -\frac{3}{2}x + \frac{9}{2} \\ &4x + 2 = -3x + 9 \\ &\qquad\qquad\qquad x = 1 \\ &\qquad\qquad\qquad y = 2 \times 1 + 1 \\ &\qquad\qquad\qquad y = 3 \\ &\qquad\qquad\qquad S = \{(1, 3)\} \end{aligned}$$

1. Solve the following systems using the appropriate method.

$$a) \begin{cases} 3x + 2y = -5 \\ 5x + 3y = -7 \end{cases}$$

$$S = \{(1, -4)\}$$

$$b) \begin{cases} x = 3y - 8 \\ x = \frac{1}{2}y - 3 \end{cases}$$

$$S = \{(-2, 2)\}$$

$$c) \begin{cases} 3x + y = -4 \\ x = 2y - 13 \end{cases}$$

$$S = \{(-3, 5)\}$$

$$d) \begin{cases} y = -2x - 3 \\ 5x + y = -3 \end{cases}$$

$$S = \{(0, -3)\}$$

$$e) \begin{cases} y = 4x + \frac{1}{2} \\ y = 2x + 1 \end{cases}$$

$$S = \left\{ \left( \frac{1}{4}, \frac{3}{2} \right) \right\}$$

$$f) \begin{cases} 4x + 3y = -28 \\ 3x - 2y = 13 \end{cases}$$

$$S = \{(-1, -8)\}$$

2. In each of the following situations,

1. identify the variables;
2. write a system of two-variable first degree equations;
3. determine the solution of the system.

a) In a real estate project, there are three times as many condominiums as single-family houses. There is a total of 240 homes. How many condominiums are there?

*x*: number of condominiums

$$x = 3y$$

*y*: number of single-family houses

$$x + y = 240$$

*There are 180 condominiums.*

b) In a warehouse, there are 1250 boxes. Each small box occupies a volume of 7 dm<sup>3</sup> and each large box occupies a volume of 45 dm<sup>3</sup>. The total volume occupied by the boxes is 42 950 dm<sup>3</sup>. How many boxes of each size are there?

*x*: number of small boxes

$$x + y = 1250$$

*y*: number of large boxes

$$7x + 45y = 42\,950$$

*There are 350 small boxes and 900 large boxes.*

c) Determine the area of a rectangle if its length is 5 m more than twice its width and the perimeter of the rectangle is equal to 37 m.

*x*: length

$$x = 2y + 5$$

*y*: width

$$2x + 2y = 37$$

*The area of the rectangle is equal to 63 m<sup>2</sup>.*

d) A car rental agency offers two options. The 1st one consists in paying a \$30 fixed amount and a \$0.08 amount per kilometre. The 2nd consists in paying a \$20 fixed amount and a \$0.10 amount per kilometre. Determine the number of kilometres that we must travel so that both options carry the same cost.

*x*: number of kilometres

$$y = 0.08x + 30$$

*y*: rental cost

$$y = 0.10x + 20$$

*The number of kilometres traveled so that the cost is the same is 500.*

# 1.4 System of two-variable first degree inequalities

## ACTIVITY 1 Solution set of a system

Consider the following system of inequalities.

$$\begin{cases} 3x + y \geq 5 & (1) \\ 2x - 3y < 7 & (2) \end{cases}$$

- Represent the solution set of inequality (1) in the Cartesian plane on the right.
- Represent the solution set of inequality (2) in the Cartesian plane on the right.
- Color the region corresponding to the set of points that verify both inequalities simultaneously.

This set of points is the **solution set** of the system.

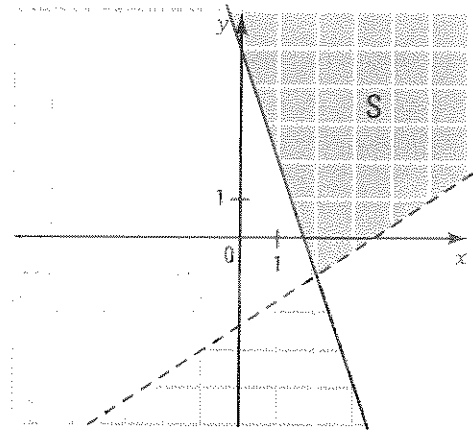

## ACTIVITY 2 At the restaurant

Ava and Richard are at a restaurant with their children. They order dishes from the daily menu at \$15 each and beverages at \$3 each. Their budget allows them to spend a maximum of \$90. They wish to order at least 4 dishes.

- Identify the variables in this situation.  
 **$x$ : number of dishes,  $y$ : number of beverages**
- Write a system of two-variable first degree inequalities that represents the constraints of this situation.

$$\begin{cases} 15x + 3y \leq 90 \\ x \geq 4 \end{cases}$$

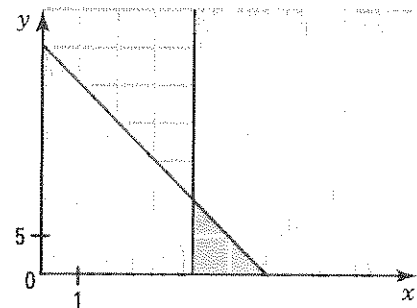

- Represent this system in the Cartesian plane on the right and color the solution set of the system.
- Give all solutions couples of the system.  $(4, 0), (4, 1) \dots (4, 10), (5, 0), (5, 1) \dots (5, 5), (6, 0)$

## SYSTEM OF TWO-VARIABLE FIRST DEGREE INEQUALITIES

- A system of two-variable first degree inequalities is a system that can be written in the form:

$$\begin{cases} a_1x + b_1y \geq c_1 & (\leq, >, <) \\ a_2x + b_2y \geq c_2 \end{cases}$$

- The solution set of a system of two-variable first degree inequalities is obtained by determining the intersection of the solution sets of each of the inequalities of the system.

Ex.: To solve the system  $\begin{cases} 3x + 5y \leq 13 \\ x > 2y - 3 \end{cases}$ , we proceed in the following way:

1 We represent the solution set of the inequality:

$$3x + 5y \leq 13$$

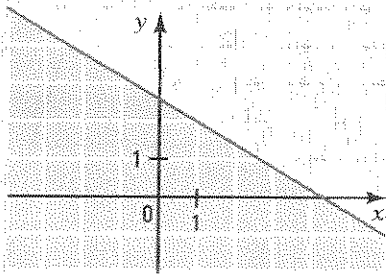

2 We represent the solution set of the inequality:

$$x > 2y - 3$$

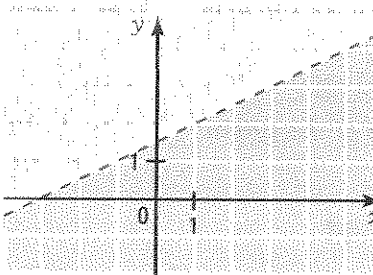

3 We deduce the solution set of the system.

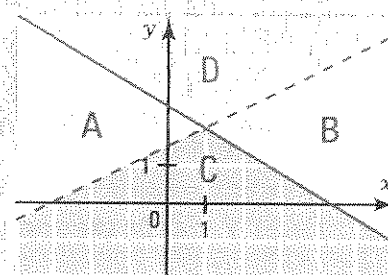

Any point belonging to region A verifies inequality (1) only.

Any point belonging to region B verifies inequality (2) only.

Any point belonging to region D verifies neither inequality.

Any point belonging to region C verifies both inequalities simultaneously and represents the solution set of the system.

1. Determine graphically the solution set of the following systems.

a)  $\begin{cases} -4x + y \leq -8 \\ x + y \leq 2 \end{cases}$

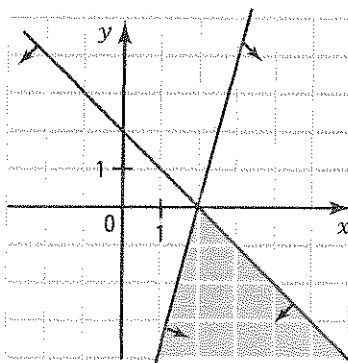

b)  $\begin{cases} y > -2x + 3 \\ x \leq 2 \end{cases}$

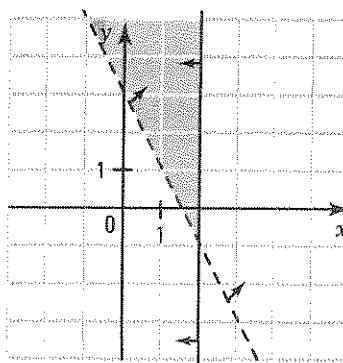

c)  $\begin{cases} x \geq -2 \\ y < 2 \end{cases}$

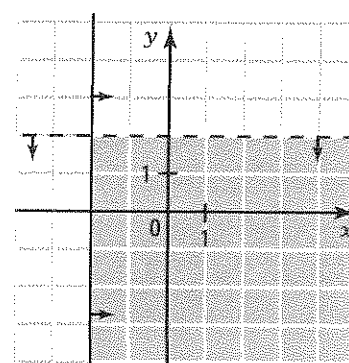



$$d) \begin{cases} x + 3y \geq 0 \\ 3x + 2y \leq 7 \end{cases}$$

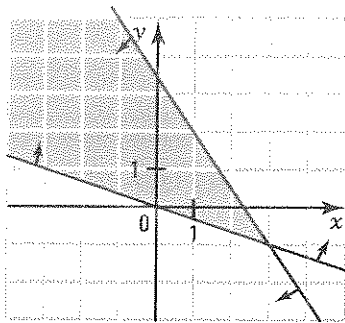

$$e) \begin{cases} x + y \leq 3 \\ x > 2y \end{cases}$$

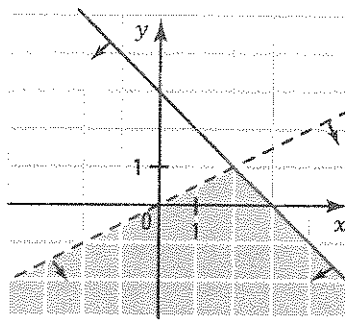

$$f) \begin{cases} 5x + 6y \leq -1 \\ x + 5y > 4 \end{cases}$$

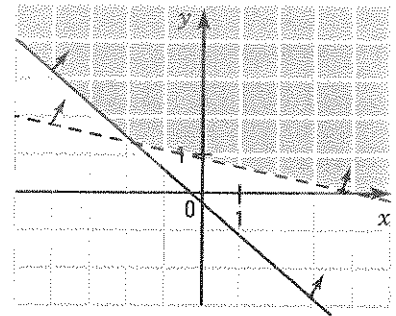

**2.** In each of the following situations

1. identify the variables involved;
2. write a system that translates the constraints of the situation;
3. represent this system in the Cartesian plane and determine the solution set.

- a) A rectangle has a height equal to at least three times its width. Its perimeter is less than 12 cm.

*x*: length, *y*: width.

$$\begin{cases} x \geq 3y \\ 2x + 2y < 12 \end{cases}$$

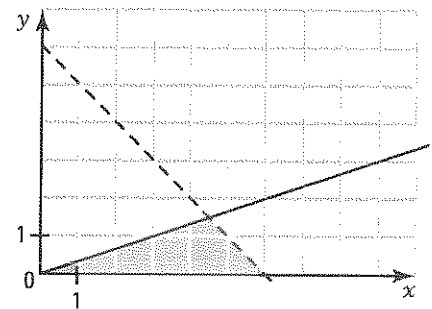

- b) In an aquarium, there are at least five more fishes as there are plants. The total number of species is at most equal to 30.

*x*: number of fishes, *y*: number of plants.

$$\begin{cases} x \geq y + 5 \\ x + y \leq 30 \end{cases}$$

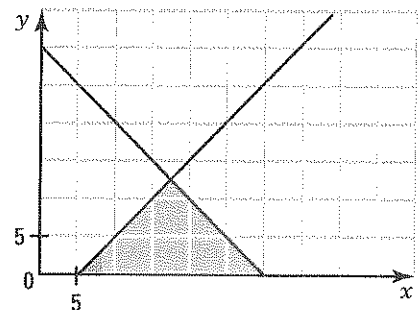

- c) In a 720 m<sup>2</sup> parking lot, each car occupies an area of 6 m<sup>2</sup> and each bus an area of 18 m<sup>2</sup>. There are less than 50 vehicles.

*x*: number of cars, *y*: number of buses

$$\begin{cases} 6x + 18y \leq 720 \\ x + y < 50 \end{cases}$$

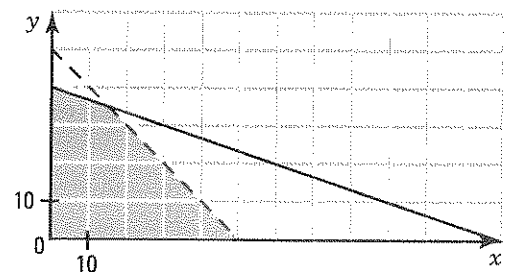

# 1.5 Polygon of constraints

## ACTIVITY 1 Constraints of a situation

To raise funds for learning disabilities, members of an association organize a concert in a theater. They want to allocate seats for donors and the rest of the seats are reserved for general admission. The theater contains a maximum of 500 seats. In order to satisfy the fundraising campaign requirements, there must be three times as many seats for general admission than seats reserved for donors. Organizers wish to have at least 50 seats reserved for donors and a maximum of 300 seats for general admission.

a) Identify the variables in this situation.

$x$ : number of seats reserved for donors.

$y$ : number of seats for general admission.

b) What are the two inequalities that translate the fact that, in a situation, the variables usually take positive or zero values?  $x \geq 0, y \geq 0$

c) Translate each of the constraints of this situation into an inequality.  $x + y \leq 500$

$y \leq 3x$

$x \geq 50$

$y \leq 300$

d) Represent each of the constraints in the Cartesian plane on the right and color the region that satisfies all the constraints.

The region obtained is a closed polygon called **polygon of constraints**.

e) Determine the vertices of the polygon of constraints.

$A(50, 0), B(50, 150), C(100, 300), D(200, 300), E(500, 0)$

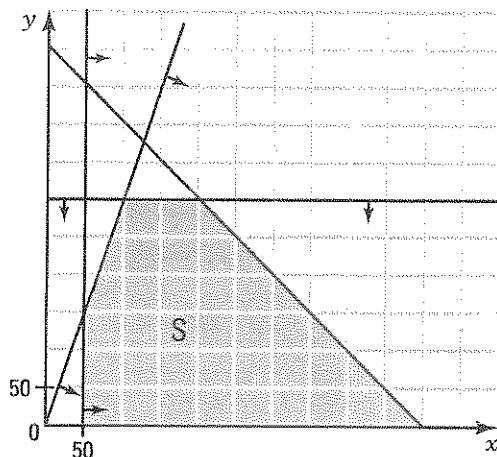

### POLYGON OF CONSTRAINTS

- A polygon of constraints is a convex polygon (open or closed) representing the solution set of a system of inequalities translating, in a situation, the constraints on the variables.
- In a situation, since the variables usually take non negative values, the polygon of constraints is represented in the 1st quadrant.

Ex.: The polygon of constraints corresponding to the solution set of the following system is represented on the right.

$$\begin{cases} x \geq 0 \\ y \geq 0 \\ x + y \leq 7 \\ x \geq 2 \\ y \geq 2 \\ x \leq 2y \end{cases}$$

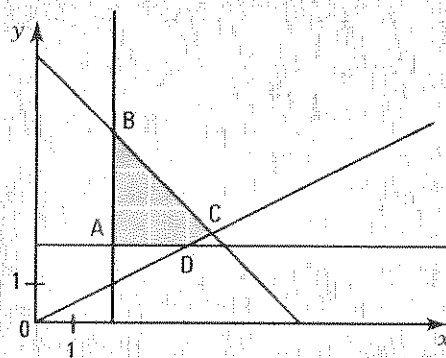

The vertices of this polygon of constraints are:  $A(2, 2)$ ,  $B(2, 5)$ ,  $C\left(\frac{14}{3}, \frac{7}{3}\right)$  and  $D(4, 2)$ .

## ACTIVITY 2 Vertices of the polygon of constraints

Consider the following system of inequalities and polygon of constraints.

$$\begin{cases} x \geq 0 \\ y \geq 0 \\ -3x + 2y \leq 1 \\ x + 7y \geq 15 \\ 4x + 5y \leq 37 \end{cases}$$

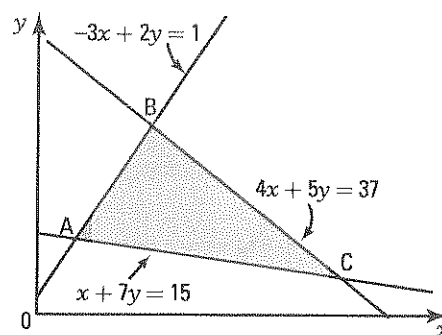

- a) What system of equations allows you to find vertex A of the polygon of constraints?

$$\begin{cases} -3x + 2y = 1 \\ x + 7y = 15 \end{cases}$$

- b) Solve this system using an appropriate method.  $A(1, 2)$

- c) Determine the polygon's other 2 vertices.  $B(3, 5), C(8, 1)$

### VERTICES OF THE POLYGON OF CONSTRAINTS

To determine the coordinates of the vertices of a polygon of constraints, we solve, for each vertex, the appropriate system of equations.

Ex.: See activity 2.

1. Determine the polygon of constraints corresponding to the solution set of each of the following systems of inequalities and find the coordinates of the polygon's vertices.

a)  $y \leq x + 2$   
 $x + y \leq 3$   
 $x - 6y \leq 3$

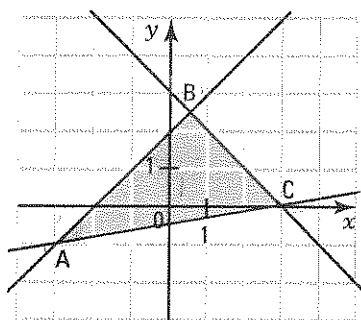

$A(-3, -1), B\left(\frac{1}{2}, \frac{5}{2}\right), C(3, 0)$

b)  $3x + 2y \leq 6$   
 $x \geq -1$   
 $x - y \leq 0$

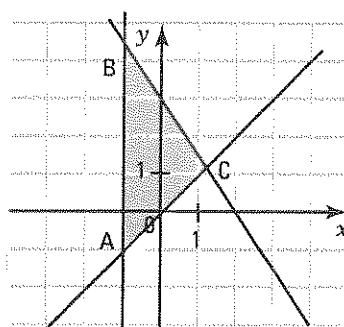

$A(-1, 1), B\left(-1, \frac{9}{2}\right), C\left(\frac{6}{5}, \frac{6}{5}\right)$

c)  $y \leq -x + 4$   
 $x - 2y \leq 4$   
 $x \geq 0$   
 $y \leq 2$

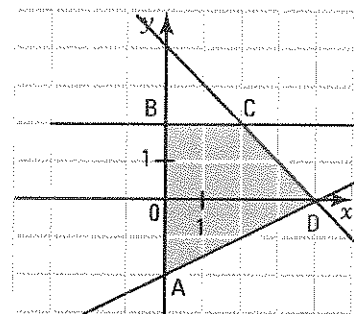

$A(0, -2), B(0, 2), C(2, 2), D(4, 0)$

2. Determine the polygon of constraints corresponding to the solution set of each of the following systems of inequalities and find the coordinates of the polygon's vertices.

a)  $x \geq 0$   
 $y \geq 0$   
 $x + y \leq 5$   
 $x \geq 2y$   
 $y \leq 1$

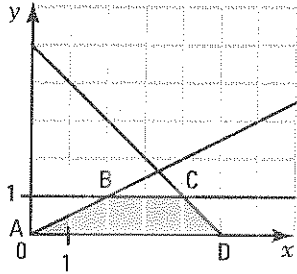

$A(0, 0), B(2, 1), C(4, 1), D(5, 0)$

b)  $x \geq 0$   
 $y \geq 0$   
 $x - y > 3$   
 $y \leq 2x$   
 $x + y < 4$

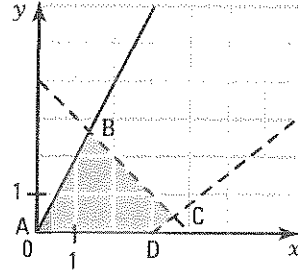

$A(0, 0), B\left(\frac{4}{3}, \frac{8}{3}\right), C\left(\frac{7}{2}, \frac{1}{2}\right), D(3, 0)$

c)  $x \geq 0$   
 $y \geq 0$   
 $x - y \leq 4$   
 $y < x + 2$   
 $y < 3$

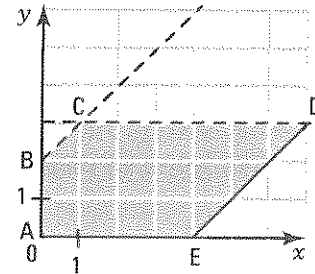

$A(0, 0), B(0, 2), C(1, 3), D(7, 3), E(4, 0)$

3. In each of the following cases, construct the polygon of constraints corresponding to the system of inequalities and determine, algebraically, the polygon of constraints' vertices.

a)  $2x - 3y \geq -8$   
 $5x + y \leq 14$   
 $3x + 4y \geq 5$

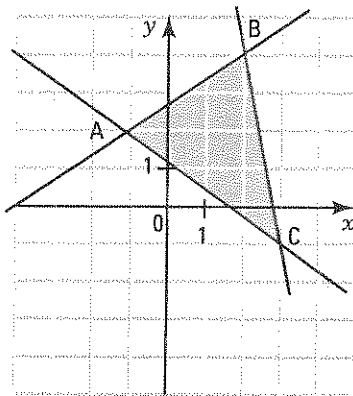

$A(-1, 2), B(2, 4), C(3, -1)$

b)  $y \geq x + 2$   
 $-x \leq 2y$   
 $x - 3y \geq -10$

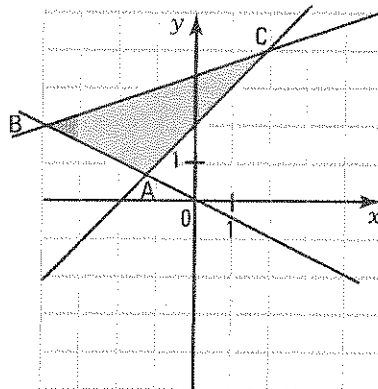

$A\left(-\frac{4}{3}, \frac{2}{3}\right), B(-4, 2), C(2, 4)$

c)  $y \leq -\frac{1}{2}x + 5$   
 $x \leq 4$   
 $4x + 5y \geq 1$   
 $y \leq 4x + 5$

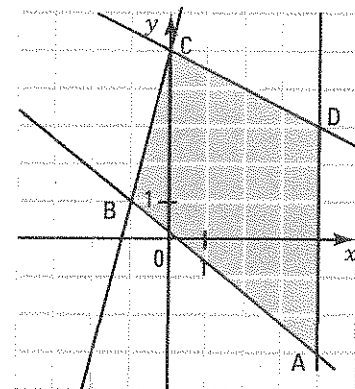

$A(4, -3), B(-1, 1), C(0, 5), D(4, 3)$

4. For each of the following situations,
1. identify the variables;
  2. determine the system of inequalities that translates the constraints of the situation;
  3. construct the polygon of constraints;
  4. determine the vertices of the polygon of constraints.

- a) A farmer grows tomatoes and potatoes on an area of at most 40 hectares. The area allotted to tomatoes is at most equal to 20 hectares. The area allotted to potatoes is at most equal to twice the area allotted to tomatoes.

*x*: number of hectares allotted to tomatoes.

*y*: number of hectares allotted to potatoes.

$$x \geq 0$$

$$y \geq 0$$

$$x \leq 20$$

$$x + y \leq 40$$

$$y \leq 2x$$

$$A(0, 0), B\left(\frac{40}{3}, \frac{80}{3}\right), C(20, 20), D(20, 0)$$

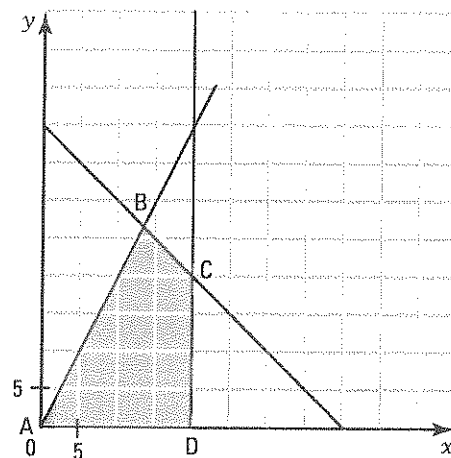

- b) A sports centre wishes to hire students for its summer camp. To meet the needs of its members, the centre must hire at most 20 students, a minimum of 6 girls, at most as many boys as girls and a maximum of 8 boys.

*x*: number of girls

*y*: number of boys

$$x \geq 0$$

$$y \geq 0$$

$$x + y \leq 20$$

$$x \geq 6$$

$$y \leq x$$

$$y \leq 8$$

$$A(6, 0), B(6, 6), C(8, 8), D(12, 8), E(20, 0)$$

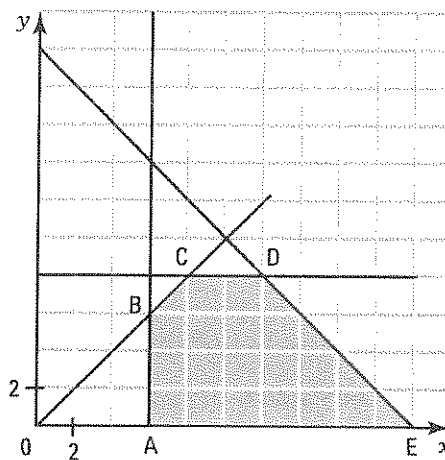

# 1.6 Optimization of a situation

## ACTIVITY 1 Two-variable function

- a) At a theater, floor seats cost \$12 and balcony seats cost \$16. Let  $x$  represent the number of floor seats sold and  $y$  the number of balcony seats sold.

Express the proceeds  $R$  of the theater as a function of the variables  $x$  and  $y$ .  $R = 12x + 16y$

- b) A company produces tables and chairs. The production costs are \$150 per table and \$50 per chair. Let  $x$  and  $y$  represent respectively the number of tables and the number of chairs produced.

Express the production cost  $C$  as a function of the variables  $x$  and  $y$ .  $C = 150x + 50y$

### OPTIMIZATION OF A FUNCTION

Optimizing a function of two variables  $x$  and  $y$  consists in finding the couple  $(x, y)$  which, depending on context, maximizes or minimizes the function.

In general, we seek the couple  $(x, y)$  which maximizes a revenue function or minimizes a cost function.

## ACTIVITY 2 Maximization of a revenue function

At the end of the season, the manager of a nursery garden wants to clear his inventory which contains 1500 flower boxes and 2000 shrubs.

Let  $x$  and  $y$  represent respectively the number of flower boxes and the number of shrubs sold.

The constraints associated with the sale of the flower boxes and shrubs are represented by the polygon of constraints on the right. The revenue  $R$  (in \$) generated by selling  $x$  flower boxes and  $y$  shrubs is given by  $R = 3x + 8y$ .

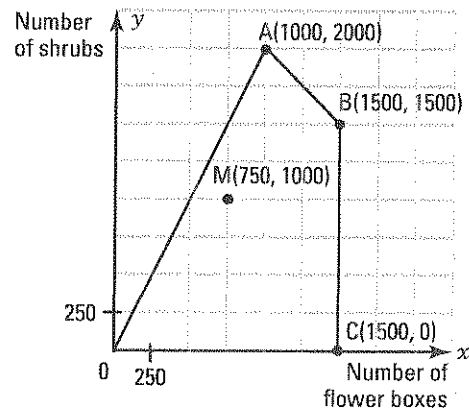

- a) The interior point  $M(750, 1000)$  of the polygon satisfies the constraints and corresponds to the sale of 750 flower boxes and 1000 shrubs. What is the revenue  $R$  generated by this sale?

$$R = 3 \times 750 + 8 \times 1000 = \$10\,250$$

- b) Evaluate, for each vertex of the polygon of constraints, the revenue associated with the sale.

Vertices	Revenue: $R = 3x + 8y$
$O(0, 0)$	$R = 3 \times 0 + 8 \times 0 = \$0$
$A(1000, 2000)$	$R = 3 \times 1000 + 8 \times 2000 = \$19\,000$
$B(1500, 1500)$	$R = 3 \times 1500 + 8 \times 1500 = \$16\,500$
$C(1500, 0)$	$R = 3 \times 1500 + 8 \times 0 = \$4500$

- c) 1. Among the vertices 0, A, B and C, which one corresponds to the maximal revenue? A  
 What is this maximal revenue? \$19 000
2. Among the vertices 0, A, B and C, which one corresponds to the minimal revenue? 0  
 What is this minimal revenue? \$0
- d) 1. Choose a random point in the interior of the polygon of constraints. Evaluate the revenue associated with the chosen point and verify that the revenue obtained is contained between the minimal revenue and the maximal revenue computed in c).  
*Various answers.*
2. What is the couple  $(x, y)$  verifying the constraints and which maximizes the revenue function? The couple (1000, 2000)  
 Interpret your result. The manager of the nursery will maximize the revenue if he sells 1000 flower boxes and 2000 shrubs. His revenue will then be equal to \$19 000.

### ACTIVITY 3 Minimization of a cost function

A company produces square tables and round tables. Let  $x$  and  $y$  represent respectively the number of square tables and the number of round tables. The constraints associated with the production of the tables are represented by the polygon of constraints on the right.

The cost  $C$  (in \$) associated with the production of  $x$  square tables and  $y$  round tables is given by  $C = 120x + 140y$ .

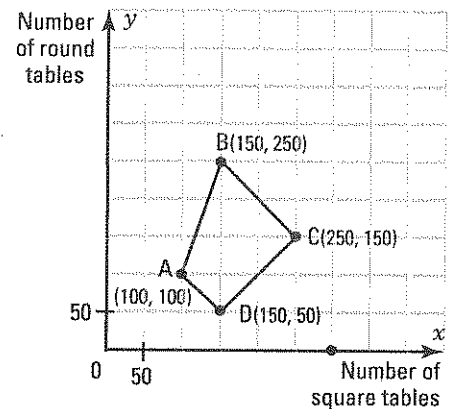

- a) Evaluate, for each vertex of the polygon of constraints, the cost associated to the production.
- b) 1. Among the vertices A, B, C and D, which one corresponds to the minimal cost? D What is this minimal cost? \$25 000
2. Among the vertices A, B, C and D, which one corresponds to the maximal cost? B  
 What is this maximal cost? \$53 000
- c) 1. Choose a random point in the interior of the polygon of constraints and verify that the cost obtained is contained between the minimal cost and the maximal cost established in b).

Vertices	Cost: $C = 120x + 140y$
A (100, 100)	\$26 000
B (150, 250)	\$53 000
C (250, 150)	\$51 000
D (150, 50)	\$25 000

- Various answers.*
2. What is the couple  $(x, y)$ , verifying the constraints, which minimizes the cost function?  
The couple (150, 50)  
 Interpret your result. The company will minimize its costs if it produces 150 square tables and 50 round tables. The cost will then be equal to \$25 000.

## ACTIVITY 4 The scanning line

At lunchtime, a cafeteria sells sandwiches and beverages. Let  $x$  and  $y$  represent respectively the number of sandwiches sold and the number of beverages sold.

The constraints associated with the sale of these items are represented by the polygon of constraints on the right.

The revenue  $R$  (in \$) generated by selling  $x$  sandwiches and  $y$  beverages is given by  $R = 2x + y$ .

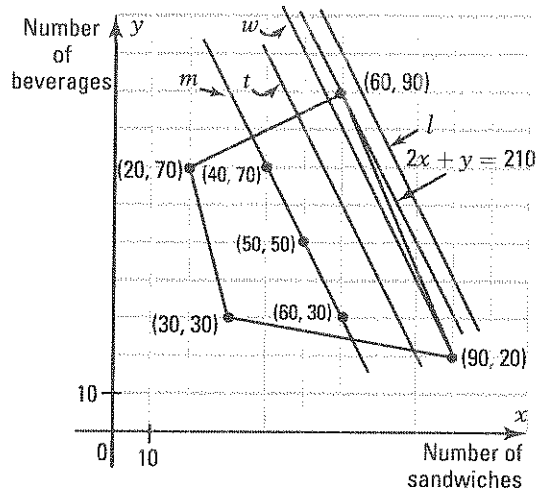

a) On Monday, the cafeteria's revenue was \$150.

- Name three possible couples  $(x, y)$  which result in this \$150 revenue and which satisfy the constraints. For example: 40 sandwiches and 70 beverages or 50 sandwiches and 50 beverages or 60 sandwiches and 30 beverages.

- The three couples obtained verify the equation of the line  $m$ :  $2x + y = 150$ . Draw line  $m$  and verify that it passes through the three points obtained in 1.

b) On Tuesday, the cafeteria's revenue was \$180.

The couples which result in a revenue of \$180 verify the equation of the line  $t$ :  $2x + y = 180$ .

- Draw line  $t$ .
- Give a point on line  $t$  which satisfies the constraints and one point which does not satisfy the constraints. (50, 80) satisfies the constraints, (40, 100) doesn't satisfy the constraints.
- Explain why lines  $m$  and  $t$  are parallel. They have the same slope.

c) When we vary the revenue  $R$  in the equation  $2x + y = R$ , the line  $2x + y = R$  moves in the same direction.

The line  $2x + y = R$  is called scanning line.

The lines  $m$ :  $2x + y = 150$  and  $m$ :  $2x + y = 180$  are thus two positions for the scanning line.

On Wednesday, the cafeteria's revenue was \$200. Give the equation of the line  $w$  corresponding to Wednesday's revenue and draw the scanning line corresponding to Wednesday.

$w: 2x + y = 200$

d) 1. Draw the line  $l$ :  $2x + y = 220$  corresponding to a position of the scanning line. Can we find, on this line  $l$ , a point  $(x, y)$  satisfying the constraints? Justify your answer.

No, because every point on the line is outside the polygon of constraints.

2. Then, is a revenue of \$220 possible? No

e) 1. What is the point of the polygon of constraints through which the scanning line giving the maximal revenue must pass? The vertex (60, 90)

2. What is the maximal revenue? \$210

3. Draw in red the scanning line passing through the point found and then give the equation of the line passing through the point found.

$2x + y = 210$



## OPTIMIZATION OF A FUNCTION UNDER CONSTRAINTS

- Given a polygon of constraints and the function to be optimized  $F = ax + by + c$ , optimizing the function  $F$  consists in determining the points, if they exist, of the polygon of constraints whose coordinates maximize or minimize, depending on context, the function  $F$ .
- If the function to be optimized possesses a maximal or minimal value, then this value is attained at, at least, one of the vertices of the polygon of constraints.
- In practice, it is sufficient to evaluate the function to be optimized at each of the vertices of the polygon of constraints to establish the maximal (or minimal) value of the function to be optimized and thus deduce the couple which maximizes (or minimizes) the function.

1. The board of directors of a music competition hires paid staff and volunteers for its fundraising campaign. The constraints associated with the hiring process are represented by the polygon of constraints below.

The function  $F$  giving the costs (in \$) associated with the hiring process is defined by  $F = 120p + 50v$  where  $p$  and  $v$  represent respectively the number of paid staff and the number of volunteers.

- a) Evaluate the function to be optimized for each vertex of the polygon of constraints.

Vertex	$F = 120p + 50v$
A(2, 2)	\$340
B(3, 5)	\$610
C(6, 7)	\$1070
D(6, 4)	\$920
E(4, 1)	\$530

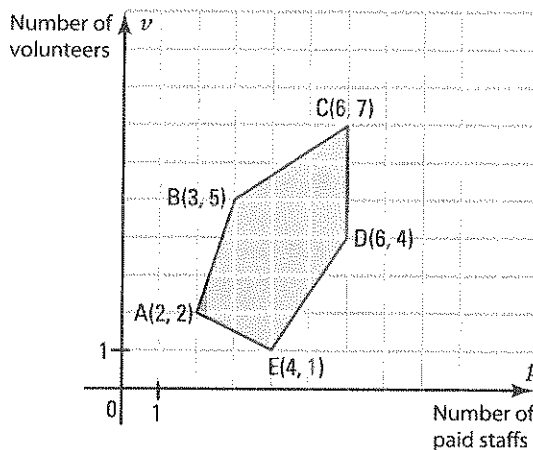

- b) 1. Taking the constraints into account, what is the minimal cost associated with the hiring process for this fundraising campaign? **\$340**
2. How many paid staffs and how many volunteers must the board hire in order to minimize costs? **2 paid staffs and 2 volunteers.**

2. The vertices of a polygon of constraints are represented on the graph on the right.

The function to be optimized is defined by  $R = 2x + 4y - 12$ .

- a) What is the couple which maximizes this function? **(7, 5)**
- b) Verify your result using the scanning line.

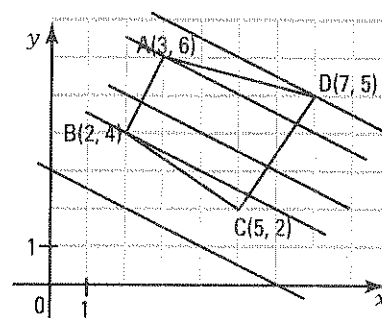

3. To raise money for their graduation party, secondary 5 students organize a car wash for cars and minivans. The students charge \$5 per car and \$10 per minivan. This event is organized with the following constraints.
- They can wash at most 100 vehicles.
  - They must wash at least 50 vehicles in order to raise enough money.
  - They expect to wash at least four times as many cars as minivans.

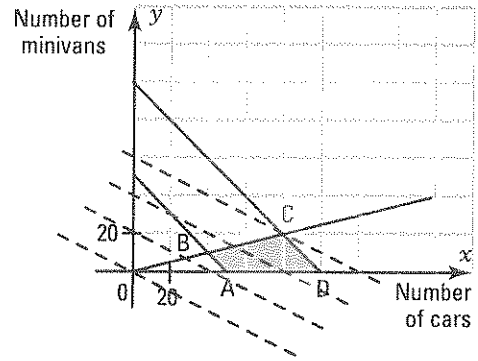

- a) Identify the variables in this situation.

$x$ : number of cars;  $y$ : number of minivans.

- b) Translate the constraints into a system of inequalities.

$$\begin{aligned} x &\geq 0 \\ y &\geq 0 \\ x + y &\leq 100 \\ x + y &\geq 50 \\ x &\geq 4y \end{aligned}$$

- c) Draw the polygon of constraints.
- d) Establish the rule of the function to be optimized.

$$R = 5x + 10y$$

- e) Evaluate the function to be optimized at each vertex of the polygon of constraints.

Vertices	$R = 5x + 10y$
A(50, 0)	250
B(40, 10)	300
C(80, 20)	600
D(100, 0)	500

- f) How many cars and minivans must the students wash in order to maximize the profit? They must wash 80 cars and 20 minivans.
- g) Verify your result by drawing the scanning line and by making it vary.

The last point of the polygon of constraints through which the scanning line passes is the point C(80, 20).

4. A cell phone company makes Nat model phones and Val model phones.

The company expects a revenue of \$40 per Nat phone and \$60 per Val phone.

To satisfy production constraints, the company must produce monthly,

- at most 400 cell phones;
- at least 150 Nat phones;
- at most 200 Val phones.

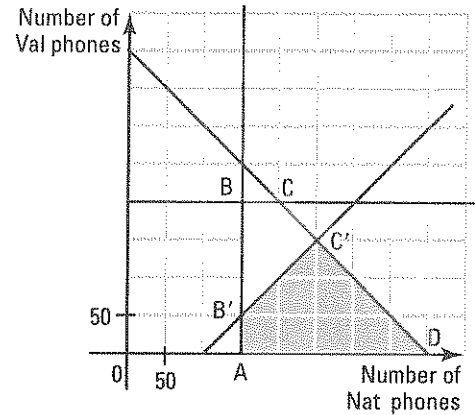

- a) Identify the variables in this situation.

$x$ : number of Nat phones;  $y$ : number of Val phones.

- b) Translate the constraints into a system of inequalities.

$$\begin{aligned} x &\geq 0 \\ y &\geq 0 \\ x + y &\leq 400 \\ x &\geq 150 \\ y &\leq 200 \end{aligned}$$

- c) Draw the polygon of constraints.

- d) Establish the rule of the function to be optimized.

$$\underline{R = 40x + 60y}$$

- e) Evaluate the function to be optimized at each vertex of the polygon of constraints.

Vertices	$R = 40x + 60y$
A(150, 0)	6000
B(150, 200)	18 000
C(200, 200)	20 000
D(400, 0)	16 000

- f) How many cell phones of each model must the company make in order to maximize its revenue?

It must make 200 Nat phones and 200 Val phones.

- g) After one week of production, the company decides to make at least 100 more Nat phones than Val phones.

Translate this additional constraint into an inequality.  $x \geq y + 100$

- h) Evaluate the function to be optimized at each vertex of the new polygon of constraints then determine the number of cell phones of each model the company must make in order to maximize its revenue.

It must make 250 Nat phones and 150 Val phones.

Vertices	$R = 40x + 60y$
A'(150, 0)	6000
B'(150, 50)	9000
C'(250, 150)	19 000
D(400, 0)	16 000

- i) Did the maximal revenue increase or decrease as a result of this additional constraint?

It decreased by \$1000.

## SOLVING AN OPTIMIZATION PROBLEM

The following steps allow us to solve an optimization problem.

1. Identify the variables.
2. Translate the constraints of the situation into a system of inequalities.
3. Draw the polygon of constraints.
4. Determine the coordinates of the vertices of the polygon of constraints.
5. Establish the rule of the function to be optimized.
6. Evaluate the function to be optimized at each vertex of the polygon of constraints.
7. Deduce the vertex whose coordinates maximize (or minimize) the function to be optimized.

5. A landscape architect was hired by a cultural centre to design the exterior of the centre. The architect must observe the following constraints.
- The total area to be landscaped is at most  $150 \text{ m}^2$ .
  - She must allot, at most,  $75 \text{ m}^2$  for a flower bed and at most  $100 \text{ m}^2$  for shrubs.
  - She must allot, at most, an area twice as large for flowers as for shrubs.

Knowing that she charges \$200 per  $\text{m}^2$  for flowers and \$125 per  $\text{m}^2$  for shrubs, what area should she allot for each type of plant in order to maximize her revenue?

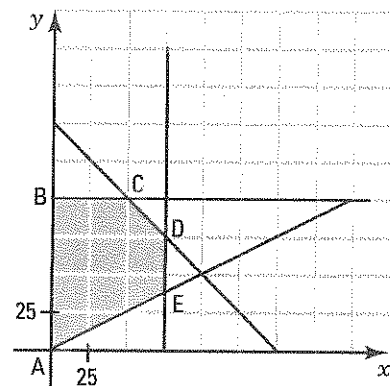

$x$ : area allotted for flowers

$y$ : area allotted for shrubs

$$x \geq 0$$

$$y \geq 0$$

$$x + y \leq 150$$

$$x \leq 75$$

$$y \leq 100$$

$$x \leq 2y$$

She must allot  $75 \text{ m}^2$  for flowers and  $75 \text{ m}^2$  for shrubs.

Vertices	$R = 200x + 125y$
$A(0, 0)$	0
$B(0, 100)$	12 500
$C(50, 100)$	22 500
$D(75, 75)$	24 375
$E(75, 37,5)$	19 687.50

## ACTIVITY 3 Non unique optimal solution

The function  $R = 1.25x + 2.50y$  gives the revenue of a baker who sells  $x$  regular croissants and  $y$  chocolate croissants.

The polygon of constraints is represented on the right.

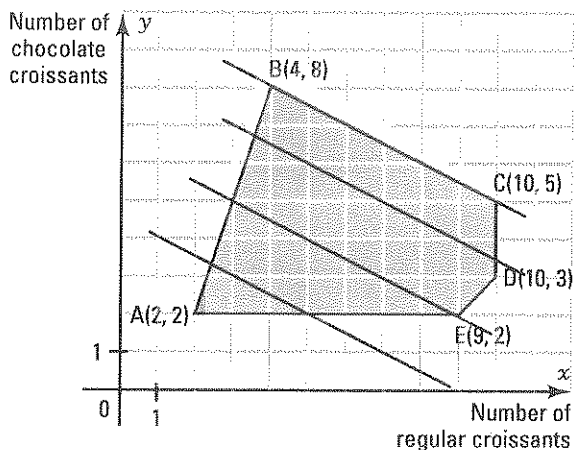

- Evaluate the revenue at each vertex of the polygon of constraints.  
A: \$7.50 B: \$25 C: \$25 D: \$20 E: \$16.25
- Verify that the revenue is maximal at the two consecutive vertices B and C of the polygon of constraints.
- Draw a few positions for the scanning line and verify that the extreme position of the wandering line that verifies the constraints is the line BC.
- What is the equation of line BC?  $1.25x + 2.50y = 25$
- Is it true that any point on edge BC of the polygon of constraints whose coordinates are integers corresponds to a sale that maximizes the revenue? True
- Give the 4 solution couples that maximize the revenue.  $(4, 8)$ ;  $(6, 7)$ ;  $(8, 6)$  and  $(10, 5)$ .

### NON UNIQUE OPTIMAL SOLUTION

If a function to be optimized attains its maximal (or minimal) value at two consecutive vertices P and Q of a polygon of constraints, then this function attains this same maximal (or minimal) value at each point of the edge PQ of the polygon.

This situation occurs when the scanning line is parallel to one of the edges of the polygon of constraints.

Ex.: See activity 3.

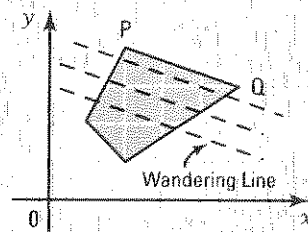

6. The polygon of constraints of an optimization problem is represented on the graph on the right.

The rule of the function to be optimized is:  $R = 3x + 6y$  where  $x$  and  $y$  are integers.

How many couples maximize function R? 4

Name them:  $(3, 6)$ ,  $(5, 5)$ ,  $(7, 4)$ ,  $(9, 3)$

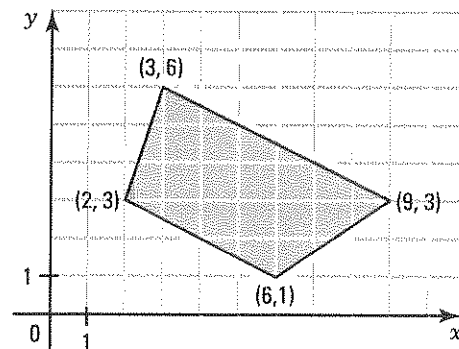

# Evaluation 1

1. Represent graphically the solution set of the following inequalities.

a)  $2x + 5y \geq 10$

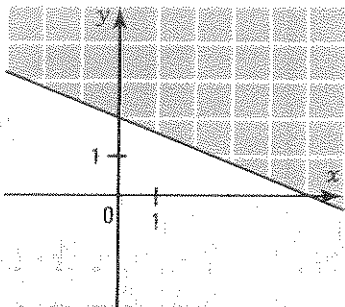

b)  $y \geq 2x - 3$

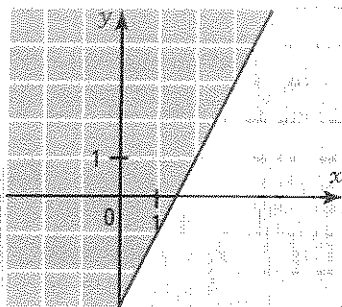

c)  $x + y < 3$

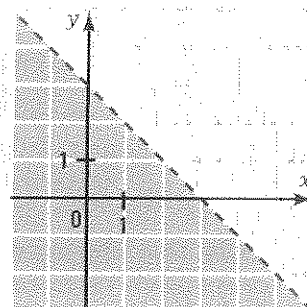

2. A bakery sells each day fresh bread and baguettes.

The price of a loaf of bread is \$3 and that of a baguette is \$1.50. In a day, the amount sold is at most equal to \$1200.

Represent this situation in the Cartesian plane.

$x$ : number of loaves of bread,  $y$ : number of baguettes.

$$3x + 1.50y \leq 1200$$

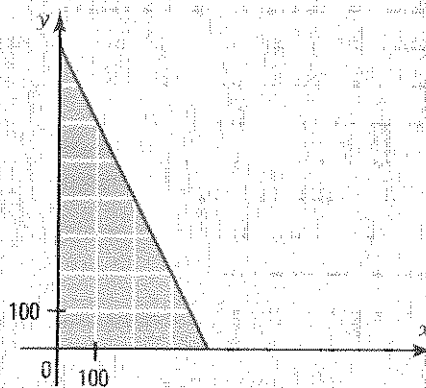

3. Represent graphically the solution set of the following systems of inequalities.

a)  $\begin{cases} 3x + 2y \leq 7 \\ x - 3y > -5 \end{cases}$

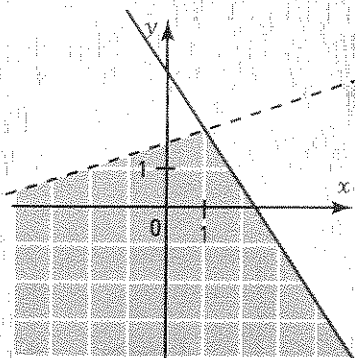

b)  $\begin{cases} y > -2x + 7 \\ x - y < 2 \end{cases}$

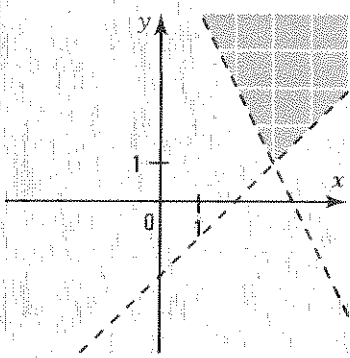

c)  $\begin{cases} x \geq -1 \\ x > 3y \end{cases}$

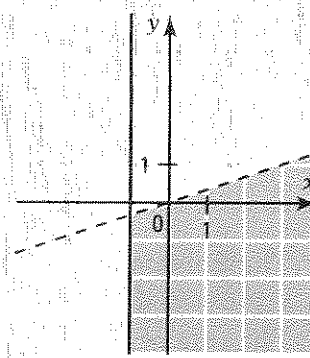

4. At a music camp, the main instruments taught are piano and violin. The camp managers expect that there will be at least twice as many campers playing piano as campers playing the violin. In addition, they expect a maximum of 300 campers playing one of these two instruments.

a) Represent this situation in the Cartesian plane;

*x*: number of campers playing piano,

*y*: number of campers playing the violin;

$$x \geq 2y$$

$$x + y \leq 300$$

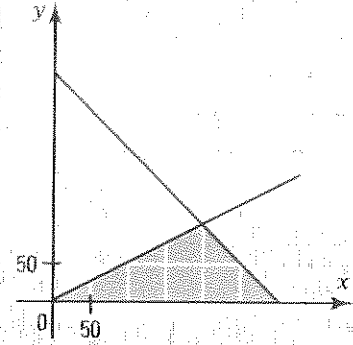

b) Give a solution couple of the system which satisfies these constraints.

*(150, 50)*. 150 campers playing piano and 50 campers playing the violin.

5. Represent, for each of the following systems of inequalities, the polygon of constraints corresponding to the solution set of the system and then determine the polygon's vertices.

a)  $-4x + 5y \leq 7$

$$x \leq 3y$$

$$x \leq 2$$

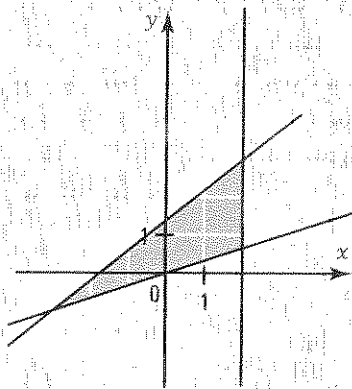

$$(-3, -1), (2, 3), \left(2, \frac{2}{3}\right)$$

b)  $2x + 3y \geq 6$

$$x \leq y + 2$$

$$y \leq 3$$

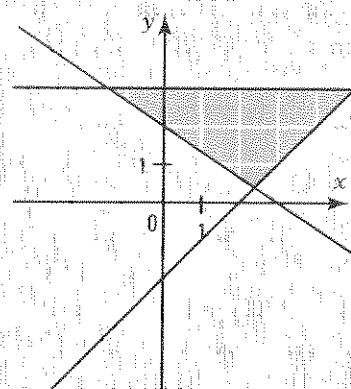

$$\left(-\frac{3}{2}, 3\right), (5, 3), \left(\frac{12}{5}, \frac{2}{5}\right)$$

c)  $y \leq \frac{5}{2}x + 4$

$$x + y \leq 4$$

$$x \leq 2y$$

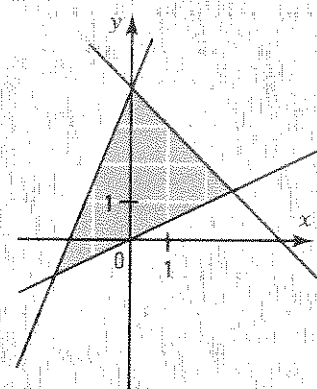

$$(-2, -1), (0, 4), \left(\frac{8}{3}, \frac{4}{3}\right)$$

- 6.** A concert is performed at the Athletes Park to raise funds for the fight against AIDS. Organizers have installed 8000 seats. They estimate that there will be at least 3000 youths under 18 and at most 4000 adults.

They want to organize this concert for at least 4000 spectators.

A youth ticket sells for \$15 and an adult ticket sells for \$25. Expenses associated with the organization of this concert are estimated at \$20 000.

What is the maximal net revenue that the organizers can obtain?

$x$ : number of youths under 18

$y$ : number of adults

$$x \geq 0$$

$$y \geq 0$$

$$x + y \leq 8000$$

$$x \geq 3000$$

$$y \leq 4000$$

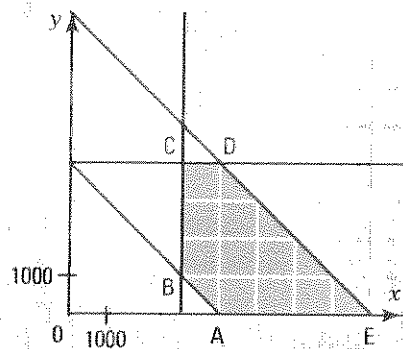

Vertices	$R = 15x + 25y - 20\,000$
A(4000, 0)	40 000
B(3000, 1000)	50 000
C(3000, 4000)	125 000
D(4000, 4000)	140 000
E(8000, 0)	100 000

The organizers can obtain a maximal net revenue of \$140 000.

- 7.** During the hockey playoffs, a shop owner decides to sell flags and caps with the Montreal Canadiens logo.

He orders 6000 items and expects to sell at least 3000 flags and at least 1000 caps. Moreover, he expects to sell at least twice as many flags as caps.

If the net profit on a flag is \$15 and that on a cap is \$12, how many flags and caps must he sell in order to maximize his profit?

$x$ : number of flags sold

$y$ : number of caps sold

$$x \geq 0$$

$$y \geq 0$$

$$x + y \leq 6000$$

$$x \geq 3000$$

$$y \geq 1000$$

$$x \geq 2y$$

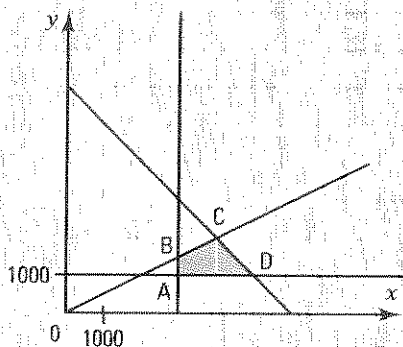

Vertices	$R = 15x + 12y$
A(3000, 1000)	57 000
B(3000, 1500)	63 000
C(4000, 2000)	84 000
D(5000, 1000)	87 000

The shop owner must sell 5000 flags and 1000 caps.



8. The graduation committee at a school organizes a cookie and muffin sale to raise money for the graduation party. The two coordinators of the committee, Laura and Russ, offer the following propositions to their members.

**Laura's proposition**

- Price of a cookie: \$2
- Price of muffin: \$3

**Polygon of constraints**

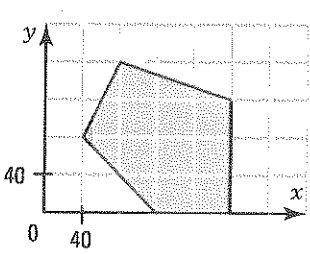

**Russ' proposition**

- Price of a cookie: \$2.50
- Price of a muffin: \$2.50

**Constraints**

The committee must sell

- a maximum of 320 items;
- at least 120 cookies;
- at most 160 muffins;
- at most 4 times as many cookies as muffins.

Let  $x$  represent the number of cookies and  $y$  the number of muffins.

Which proposition should the committee accept in order to maximize profits?

*Laura*

Vertices	$R = 2x + 3y$
(120, 0)	240
(40, 80)	320
(80, 160)	640
(200, 120)	760
(200, 0)	400

*Russ:*

$$\begin{aligned} x &\geq 0 \\ y &\geq 0 \\ x + y &\leq 320 \\ x &\geq 120 \\ y &\leq 160 \\ x &\leq 4y \end{aligned}$$

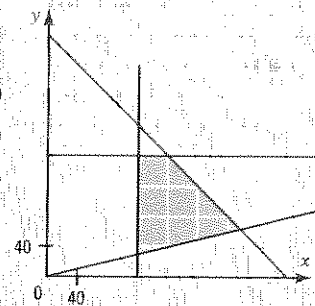

Vertices	$R = 2.50x + 2.50y$
(120, 30)	375
(120, 160)	700
(160, 160)	800
(256, 64)	800

*Russ' proposition achieves a better profit.*

