

# JUNE EXAM TOPICS CHECKLIST

Secondary 3  
Regular

## Real Numbers

- Pythagorean Theorem
- Types of Numbers
- Exponents
- Scientific Notation
- Convert to fraction

## Algebra

- Monomials
- Polynomials
- Adding like terms
- Distributive Property
- FOIL
- Dividing
- Area of Polygons
- Removing common factor
- Finding numerical value

## Inequality

- Intervals
- Graphic representation

## Linear Equations

- Mathematical Phrases
- Solving  $x$  in an equation
- Solving a word problem
- Finding the slope
- Finding the equation of a line
- Graphing an equation
- Direct, Constant, Partial Function
- Comparison Method

## Functions

- Rational Function

## Surface Area and Volume

- Decomposable Shapes
- Finding the height
- Converting units

## Similar Figures

- Scale factor
- Missing measures

## Statistics

- Mode, Median, Mean, Range
- Histograms
- Frequency table
- Stem and Leaf
- Weighted Mean
- Stratified Sampling Method
- Box and Whisker

## Probability

- Describe extensively
- Describe in words
- Geometric Probability
- Probability tree Diagram
- With and Without Replacement

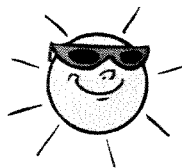

It was a pleasure!  
Have an awesome summer!



**Part A**      **Questions 1 to 8**  
Darken the letter that represents your choice on the  
**Multiple-Choice Answer Sheet.**

1

4 0

Susan is a manager at a clothing boutique. She receives a base salary of \$200 plus \$8 per hour. Her weekly salary is represented in the following table:

**Susan's salary according to hours worked**

x (hours)	10	20	30	40
y (\$)	280	360	440	520

Which of the following rules describes the situation above?

A)  $y = 8x$

C)  $y = 200x + 8$

B)  $y = 10x + 280$

D)  $y = 8x + 200$

2

4 0

Vanessa is teaching a dance class. Each person attending the class is charged \$12. Vanessa must pay \$75 to rent the room.

Which of the following equations represents her earnings,  $E$ , if  $p$  represents the number of people attending the class?

A)  $E = 12p + 75$

C)  $E = 12 - 75p$

B)  $E = 12p - 75$

D)  $E = 12 + 75p$



3

4 0

Which of the following expressions is equivalent to:

$$\frac{5^4 \times 10^7}{5^2 \times 10^9}$$

A)  $2.5 \times 10^{-3}$

C)  $2.5 \times 10^{-1}$

B)  $2.5 \times 10^{-2}$

D)  $2.5 \times 10^2$

~~4~~

4 0

The triangle ABC below undergoes a transformation given by the rule:

$$S_y \circ S_x \circ r(0, -90^\circ)$$

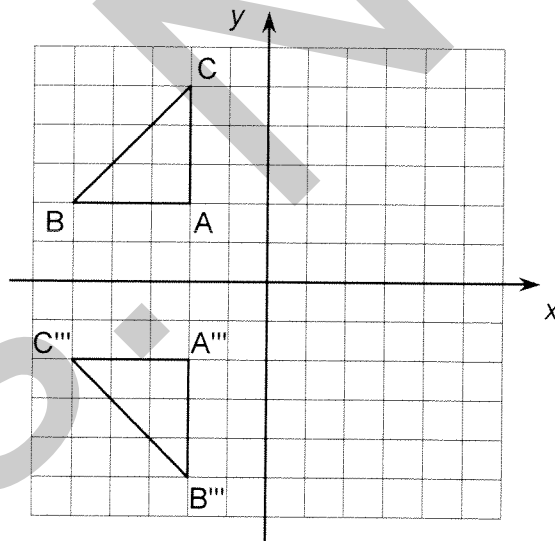

What is the equivalent single transformation represented by the composite transformation?

A) Glide reflection

C) Rotation

B) Reflection

D) Translation

~~7~~

4 0

A prism has 8 vertices and 12 edges.

**What kind of prism is it?**

- A) Triangular prism
- B) Rectangular prism
- C) Pentagonal prism
- D) Hexagonal prism

8

4 0

Given the following distribution:

1, 2, 3, 4, 7, 7, 8, 8

**What are the median and range of the above data?**

- A) Median = 5  
Range = 7
- B) Median = 5  
Range = 8
- C) Median = 5.5  
Range = 7
- D) Median = 5.5  
Range = 8

**Part B Questions 9 to 15**

Show all appropriate work.  
Write your answer in the space provided.

9

4	3	2	1	0
---	---	---	---	---

Match each graph with the equation that best represents it.

**Graphs**

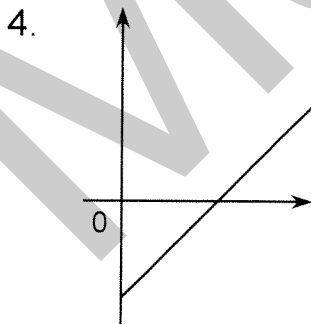
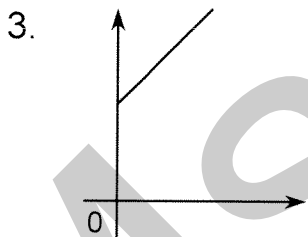
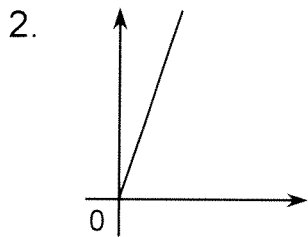
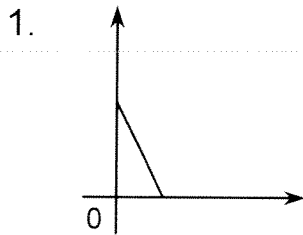

**Equations**

A)  $y = 3x$

B)  $y = x - 5$

C)  $y = 5$

D)  $y = -x - 5$

E)  $y = -2x + 5$

F)  $y = x + 5$

Answer:

Graphs	Equations
1	
2	
3	
4	



10

4 3 2 1 0

- a) A square is inscribed inside a circle with diameter 24 cm.

**What irrational number represents side  $a$ ?**

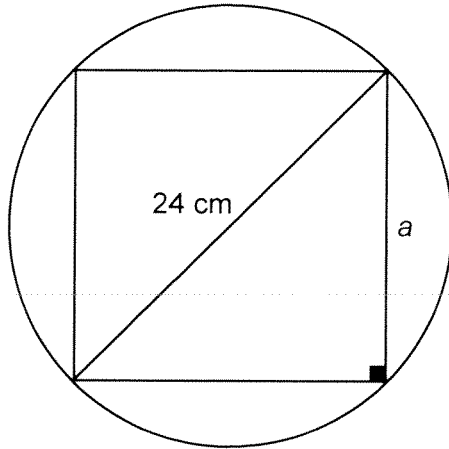

Answer: The irrational number is \_\_\_\_\_ cm.

- b) Triangle ABC below is a right angle triangle. Several measurements are shown on the diagram.

**What is the length of  $\overline{DC}$ ?**

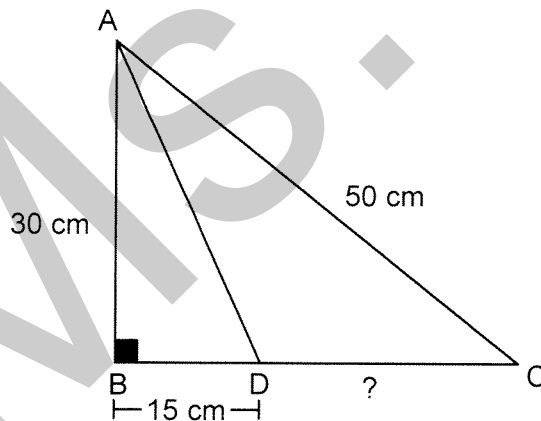

Answer: The length of  $\overline{DC}$  is \_\_\_\_\_ cm.

11

4	3	2	1	0
---	---	---	---	---

The relation between the time (T) it will take a train to complete a 400 km trip, and its speed (s) is given by the following rule :

$$T = \frac{400}{s}$$

a) Complete the table of values below:

Speed of train vs. Time

Speed (s) (km/h)	40	80	100	160	200
Time (T) (h)					

b) Draw the graph of this relation.

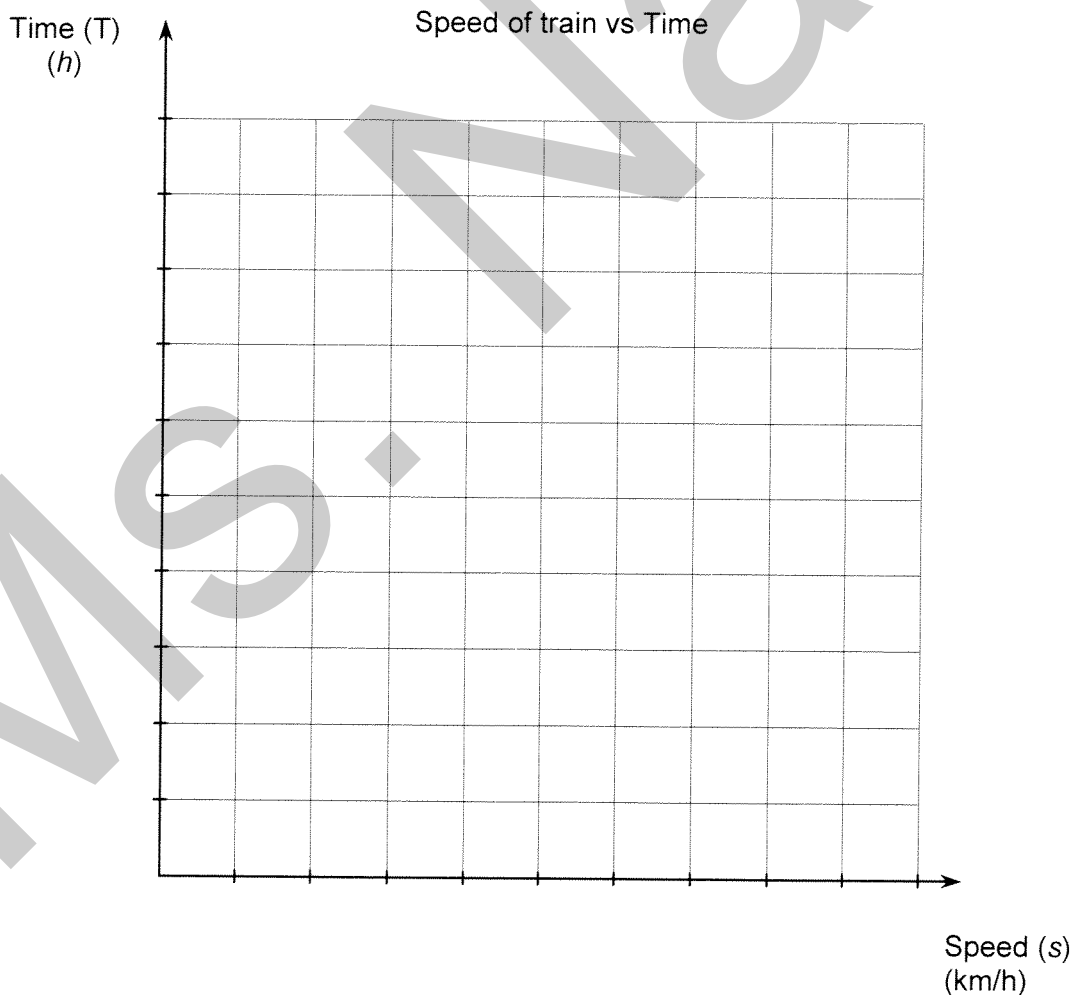

12

4 2 0

Simplify the following.

a)  $3a^2b^4 + (2ab^2)^2 - 7(ab)^0$

Answer: \_\_\_\_\_

- b) The algebraic expression for the perimeter of triangle ABC is  $18a + 12$ .

m  $\overline{AB}$  =  $6a - 1$

m  $\overline{AC}$  =  $5a + 4$

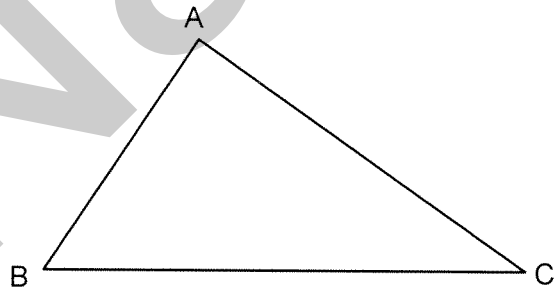

What simplified algebraic expression represents m  $\overline{BC}$ ?

Answer: The simplified algebraic expression is \_\_\_\_\_.



13

4 2 0

Convert the measures below into the indicated units.

a)  $0.37 \text{ dm}^3 = \underline{\hspace{2cm}} \text{ mm}^3$

b)  $2.63 \text{ L} = \underline{\hspace{2cm}} \text{ cm}^3$

$$1 \text{ mL} = 1 \text{ cm}^3$$

c)  $3.8 \text{ mL} = \underline{\hspace{2cm}} \text{ mm}^3$

d)  $45.6 \text{ cm}^3 = \underline{\hspace{2cm}} \text{ dm}^3$



15

4 3 2 0

The following table represents the number of hours that a group of 32 students worked in a week. They are arranged in numerical order.

0	0	0	0	5	6	8	8	8	10	12
15	15	17	18	18	18	20	20	20	22	24
24	24	25	28	28	30	32	34	36	38	

Fill out the frequency table below and construct a histogram for the given data. Title and label the histogram.

Number of hours a week that students work

Number of hours worked (h)	Frequency
[0, 8[	

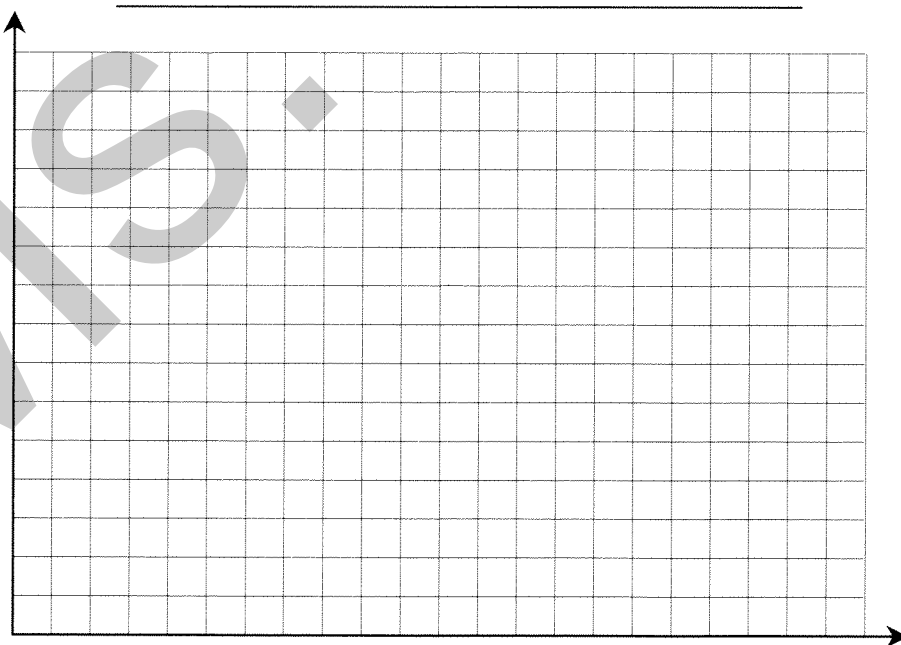

16

4 3 2 1 0

A metal piece is composed of a hemisphere and a cylinder.

The radius of the hemisphere is 10 cm and the radius of the cylinder is 6 cm.

The total height of the metal piece is 18 cm.

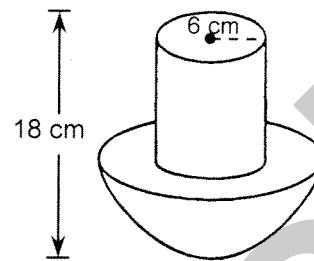

**What is the volume of the metal piece?**

Show your work.

The volume of the metal piece is \_\_\_\_\_  $\text{cm}^3$ .

17

4	3	2	1	0
---	---	---	---	---

The cube and the sphere below have the same total surface areas.  
The edge of each side of the cube measures 4 cm.

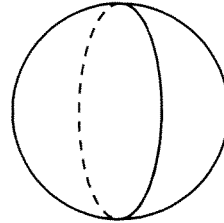
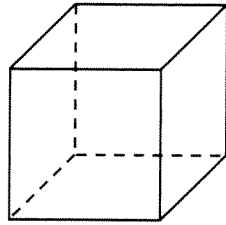

To the nearest hundredth of a centimetre, what does the radius of the sphere measure?

Show your work.

To the nearest hundredth of a centimetre, the radius of the sphere measures \_\_\_\_\_ cm.

18

4	3	2	1	0
---	---	---	---	---

A block of modelling clay, in the shape of a right prism, is shown below. It measures 40 cm by 15 cm by 15 cm.

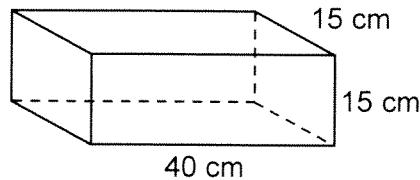

All the clay from the prism is used to construct a cone, as shown. The diameter of the cone is 20 cm.

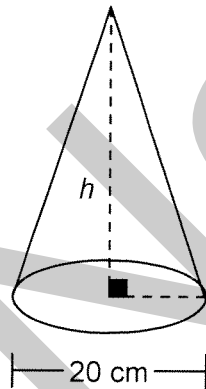

**What is the height of the cone to the nearest centimetre?**

Show your work.

To the nearest centimetre, the height of the cone is \_\_\_\_\_ cm.

19

4	3	2	1	0
---	---	---	---	---

A school needs to order Secondary III math books from Publishers Inc. The cost is represented on the graph below. A \$50 delivery charge is included in the price.

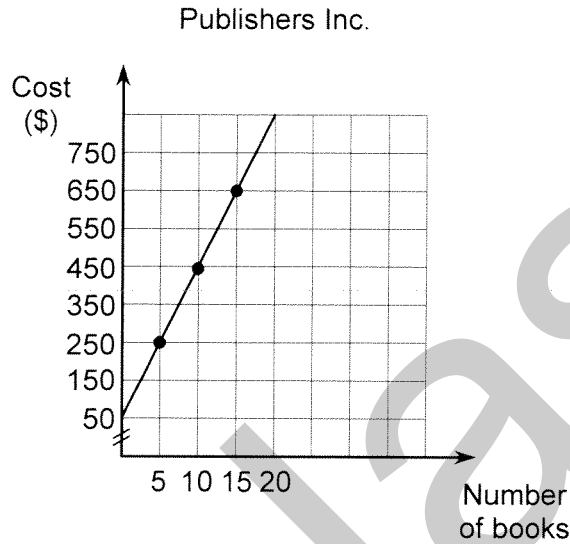

**How much will 120 math books cost?**

Show your work.

120 math books will cost \$ \_\_\_\_\_.

20

4	3	2	1	0
---	---	---	---	---

The dining room and the hallway of a hotel have the same areas, but their perimeters are different. The algebraic expression for some of the dimensions are given in the diagram below.

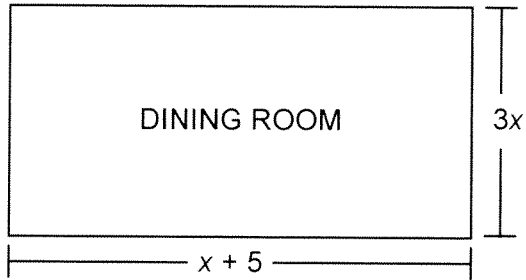

**What is the difference between the perimeter of the hallway and the perimeter of the room?**

Show your work.

The difference between the two perimeters is \_\_\_\_\_ units.

21

4	3	2	1	0
---	---	---	---	---

The figure below is composed of a square, a triangle, and a rectangle. The algebraic expressions for some of the dimensions are given.

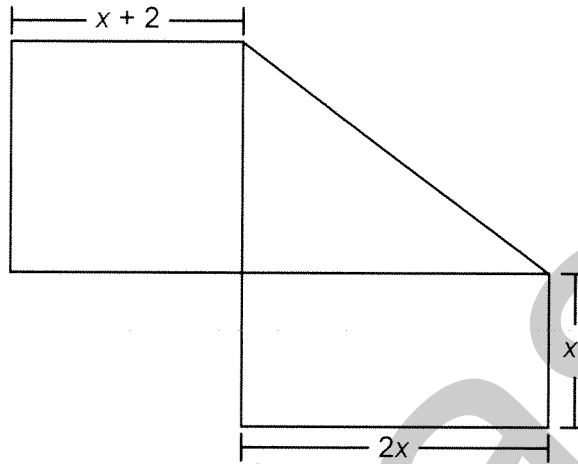

**What is the simplified algebraic expression for the total area of the figure?**

Show your work.

The simplified algebraic expression for the total area of the figure is

---





22

4	3	2	1	0
---	---	---	---	---

The frame of a roof in the shape of an isosceles triangle,  $ABC$ , is shown on the right. Segments  $AB$  and  $CB$  are congruent.

Support beams  $\overline{PM}$  and  $\overline{QM}$  strengthen the frame.  $\angle BPM$  and  $\angle BQM$  are right angles.

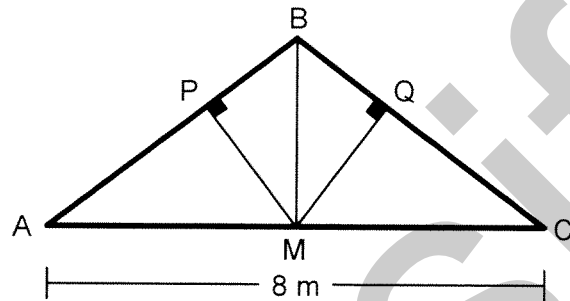

The perimeter of the frame is 18 m.

The base of the frame,  $\overline{AC}$ , is 8 m and the height,  $\overline{BM}$ , is 3 m.

Points  $P$  and  $Q$  are situated  $\frac{16}{25}$  along the lengths of  $\overline{AB}$  and  $\overline{CB}$ , starting from points  $A$  and  $C$ , respectively.

**What is the length of support beam  $\overline{PM}$ ?**

Show your work.

The length of support beam  $\overline{PM}$  is \_\_\_\_\_ m.



23

4	3	2	1	0
---	---	---	---	---

Following is a list of numbers in a given distribution.

50, 60, 70, 60, 40, 100, 80, 50, 50, 80

A second distribution is made up of 5 numbers. It has the same mode, the same median and the same mean as the first distribution.

It has a range of 40 and the mode is the smallest number.

**What are the 5 numbers of the second distribution?**

Show your work.

The 5 numbers are \_\_\_\_\_, \_\_\_\_\_, \_\_\_\_\_, \_\_\_\_\_, \_\_\_\_\_.

**Part A**

**Questions 1 to 8**

Darken the letter that represents your choice on the **Multiple-Choice Answer Sheet.**

**1** The following table gives the cost of renting a paintball facility.

$x$ (number of participants)	0	2	4	6
$y$ (cost in dollars)	200	224	248	272

**What is the rule that describes the cost of renting the facility?**

- A)  $y = 200$
- B)  $y = 200x + 24$
- C)  $y = 24x + 200$
- D)  $y = 12x + 200$

**2** A school collected donations for a disaster relief fund over a 7-day period, as shown in the accompanying graph.

They started with an initial amount of \$500 and ended with \$1025.

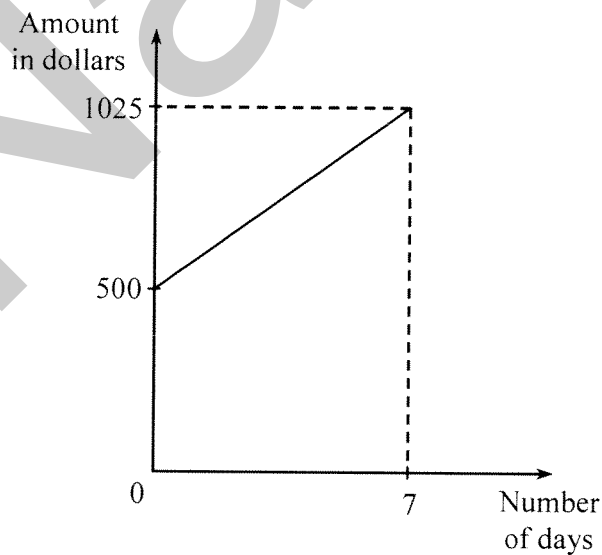

**What is the rate of change?**

- A) \$75.00 per day
- B) \$146.43 per day
- C) \$217.86 per day
- D) \$71.43 per day

7

A model is made by connecting a cone, a cylinder, and a cube.

- The height of the cylinder is 16 cm.
- The height of the cone is half the height of the cylinder.
- The cube and the cone have the same height.

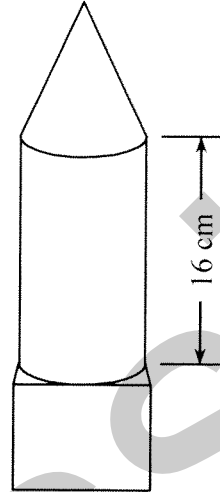

**What is the total volume of the model?  
(Round to the nearest whole number.)**

- A)  $981 \text{ cm}^3$                       C)  $1718 \text{ cm}^3$   
B)  $1450 \text{ cm}^3$                       D)  $4265 \text{ cm}^3$

8

A group of students had the following scores on a math quiz:

55, 60, 68, 75, 75, 79, 80, 82, 83

**What number can be added to these scores in order to keep the median the same?**

- A) 75                      C) 77  
B) 76                      D) 79

**Part B Questions 9 to 15**

Show all appropriate work.  
Write your answer in the space provided.

**9**

The relation between the number of people ( $n$ ) it takes to paint the walls of a cafeteria and the time required in hours ( $T$ ) is given by the following table:

Number of People vs. Time				
$n$ (number of people)	2	3	4	6
$T$ (time in hours)	18	12	9	6

In your Answer Booklet, **graph the relation. Label your graph.**

**10**

A rectangular doorway measures 200 cm by 75 cm.

**Could a circular mirror measuring 220 cm in diameter be passed sideways through this opening?**

Calculation:

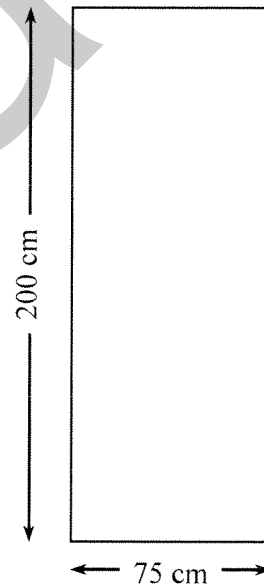

11

- a) What is the rate of change for the graph below?

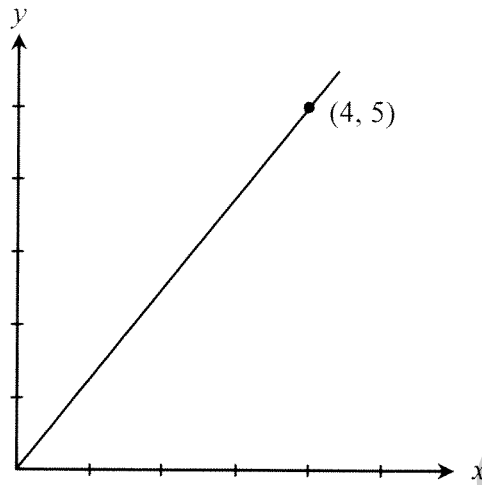

- b) Pat joined a gym. It costs him \$30 per month to be a member.

What rule could be used to represent the relation between months and total cost?

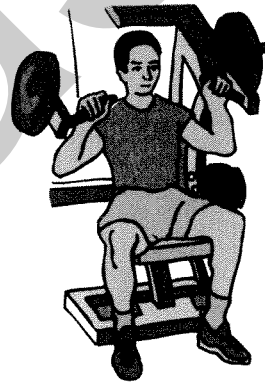

12

**Simplify**

a) 
$$\frac{12a^4 - 6a^2 + 9a}{3a}$$

**Expand**

b)  $(3x - 4)^2$

**13** Convert the measures below into the indicated units:

a)  $14.5 \text{ dam}^3 = \underline{\hspace{2cm}} \text{ m}^3$

b)  $150 \text{ dL} = \underline{\hspace{2cm}} \text{ cm}^3$

**14** The vertices of quadrilateral ABCD on a Cartesian plane have the following coordinates: A(-6, 8), B(-9, 5), C(-3, 4), D(-3, 6)

The following composite transformation is used to produce quadrilateral A''B''C''D'':

$$r_{(0, 90^\circ)} \circ S_x$$

In your Answer Booklet, **give the coordinates of the following vertices. Construct the image of quadrilateral ABCD by applying the given composite transformation.**

**15** The table below lists the heights, in cm, of the 20 students in Ms. Saha's math class.

180	167	170	168	160	178	171	169
167	169	163	173	171	168	175	165
166	172	170	169				

- a) In your Answer Booklet, **fill out the frequency table using the data above.**
- b) In your Answer Booklet, **construct a histogram to represent the data. Title and label your histogram.**

**Part C Questions 16 to 23**

- ▶ Answer each question in the space provided below the question. Each question is worth 4 marks.
- ▶ **Show all your work as well as your answer.** The work shown is taken into consideration when marks are awarded.
- ▶ Your written information must be legible, complete, and clearly stated in correct language so the marker understands exactly what you have done.

**Even if your answer is correct, no marks will be given unless acceptable work is shown.**

**16**

Jossia's aboveground pool holds 50 000 litres of water.  
The pool developed a leak.  
The accompanying linear graph shows that after 2 hours, 38 000 litres of water remain in the pool, while after 4 hours, 26 000 litres remain.

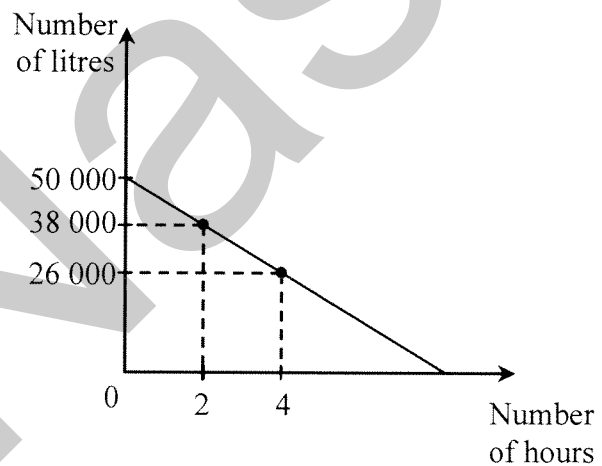

**How many litres of water remain in the pool after 7 hours?**

Show all your work.

**17**

Calvin's cat is stuck in a tree.  
The cat is 9 m above the ground.  
A person trying to rescue the cat places an 8 m ladder 3.5 m from the base of the tree.

**To the nearest tenth of a metre, how far is the cat from the top of the ladder?**

Show all your work.

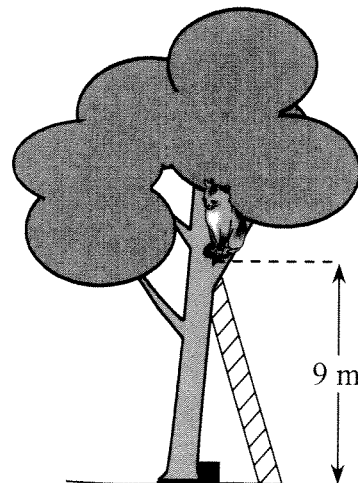





18

The perimeter of the rectangular room on the right is  $(30x + 18)$  metres.  
The width is  $(3x - 2)$  metres.  
Logan wants to install a carpet that covers the entire floor.

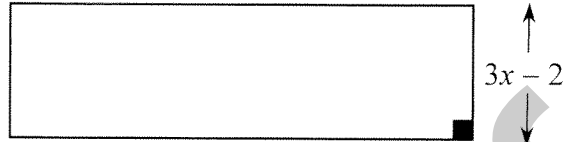

**How many square metres of carpet are needed to cover the floor?**

Express your answer as a simplified algebraic expression.

Show all your work.

19

The floor of a wooden deck is designed such that there is a space set aside for a HOT TUB.

**What is the area of the wooden portion of the deck?**

Give your answer in simplified algebraic form.

Show all your work.

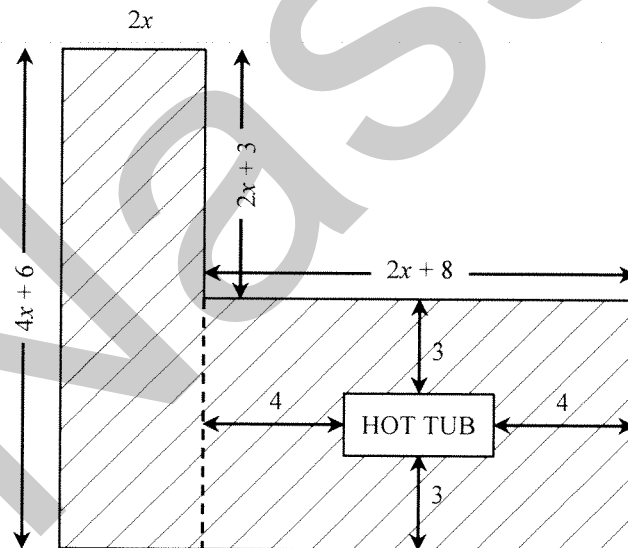

20

A cube with volume of  $125 \text{ dm}^3$  is cut diagonally, as shown in the diagram.

**What is the area of the shaded triangular face, to the nearest hundredth  $\text{dm}^2$ ?**

Show all your work.

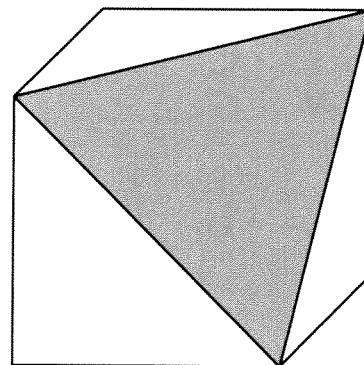

21

Netting is required to enclose a cage for golfers to practice at the GOLF DOME.

The cage is in the form of a rectangular prism with a half-cylindrical top. **No** netting is required for the front opening or the floor.

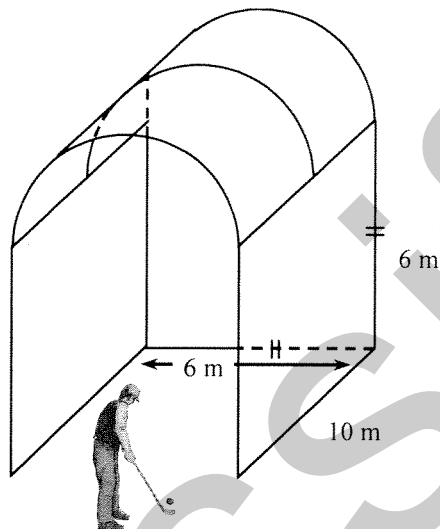

Using the dimensions shown on the diagram, how much netting, to the nearest square metre, is required to enclose the cage?

Show all your work.

22

The view on the right represents a cross-section of a plastic bottle composed of a hemisphere, a large cylinder, and a small cylinder.

When only the hemisphere and large cylinder are filled, the bottle holds 500 mL of water.

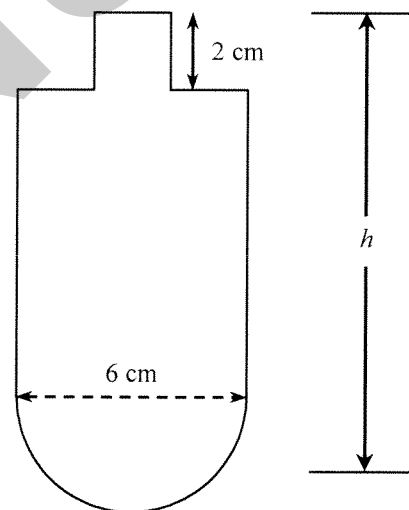

To the nearest tenth of a centimetre, what is the total height,  $h$ , of the bottle?

Show all your work.

23

The Montreal Expos Baseball Club played their final season in 2004. The number of wins in 18 of their last 20 seasons is listed, in descending order, in the following chart.

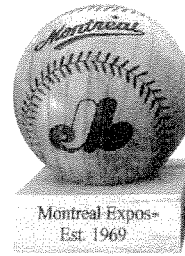

94	91	88	87	85
84	83	83	81	81
74	71	68	68	67
67	66	65		

In each of the two seasons that are missing, the team won the **same** number of games. The mean number of wins for all 20 seasons was 77.95.

**What is the median number of wins for the 20 seasons?**

Show all your work.